

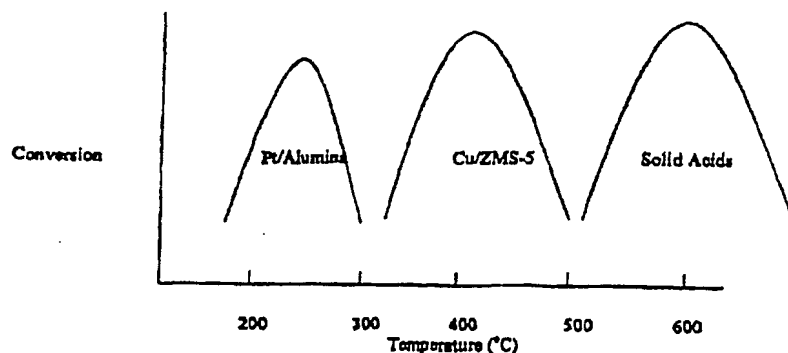

## INTERNATIONAL APPLICATION PUBLISHED UNDER THE PATENT COOPERATION TREATY (PCT)

(51) International Patent Classification <sup>7</sup> : <b>C10K</b>	<b>A2</b>	(11) International Publication Number: <b>WO 00/43469</b>
		(43) International Publication Date: 27 July 2000 (27.07.00)
<p>(21) International Application Number: PCT/US00/01574</p> <p>(22) International Filing Date: 21 January 2000 (21.01.00)</p> <p>(30) Priority Data: 60/116,791 21 January 1999 (21.01.99) US</p> <p>(71) Applicant: LITEX, INC. [US/US]; 2235 Massachusetts Avenue, Cambridge, MA 02140 (US).</p> <p>(72) Inventors: CAREN, Robert, P.; 6039 Glencagles Circle, San Jose, CA 95138-2373 (US). TRUEX, Timothy; 1241 Coronet Drive, Riverside, CA 92506 (US).</p> <p>(74) Agents: WEILD, David, III et al.; Pennie &amp; Edmonds LLP, 1155 Avenue of the Americas, New York, NY 10036 (US).</p>	<p>(81) Designated States: AE, AL, AM, AT, AU, AZ, BA, BB, BG, BR, BY, CA, CH, CN, CR, CU, CZ, DE, DK, DM, EE, ES, FI, GB, GD, GE, GH, GM, HR, HU, ID, IL, IN, IS, JP, KE, KG, KP, KR, KZ, LC, LK, LR, LS, LT, LU, LV, MA, MD, MG, MK, MN, MW, MX, NO, NZ, PL, PT, RO, RU, SD, SE, SG, SI, SK, SL, TJ, TM, TR, TT, TZ, UA, UG, UZ, VN, YU, ZA, ZW, ARIPO patent (GH, GM, KE, LS, MW, SD, SL, SZ, TZ, UG, ZW), Eurasian patent (AM, AZ, BY, KG, KZ, MD, RU, TJ, TM), European patent (AT, BE, CH, CY, DE, DK, ES, FI, FR, GB, GR, IE, IT, LU, MC, NL, PT, SE), OAPI patent (BF, BJ, CF, CG, CI, CM, GA, GN, GW, ML, MR, NE, SN, TD, TG).</p> <p><b>Published</b> <i>Without international search report and to be republished upon receipt of that report.</i></p>	

(54) Title: COMBINED PLASMA REACTOR CATALYST SYSTEMS FOR EFFECTIVE EMISSION CONTROL OVER A RANGE OF OPERATING CONDITIONS



## (57) Abstract

The invention is directed to an apparatus and a method for removing at least a portion of at least one pollutant in an exhaust gas stream containing exhaust gas formed from the combustion of fuel in a lean burn engine. The apparatus has at least one device for removing at least a portion of at least one of oxides of nitrogen, hydrocarbons, carbon monoxide, and particulates in the exhaust gas, the device having an inlet and an outlet, wherein the device is selected from the group consisting of selective catalytic reduction catalysts, particulate traps, selective catalytic reduction catalyst coated particulate traps, oxide of nitrogen storage and reduction catalysts, oxidation catalysts, and three-way catalysts, and is positioned, such that at least a portion of the exhaust gas stream from the lean burn engine passes through the device; and at least one device for producing a non-thermal plasma in at least a portion of the exhaust gas stream. At least a portion of the exhaust gas stream is exposed to the non-thermal plasma, and at least a portion of that portion of the exhaust gas stream exposed to the non-thermal plasma is introduced into the exhaust gas stream at a point upstream of or at the at least one device for removing at least one of oxides of nitrogen, hydrocarbons, carbon monoxide, and particulates.

*FOR THE PURPOSES OF INFORMATION ONLY*

Codes used to identify States party to the PCT on the front pages of pamphlets publishing international applications under the PCT.

AL	Albania	ES	Spain	LS	Lesotho	SI	Slovenia
AM	Armenia	FI	Finland	LT	Lithuania	SK	Slovakia
AT	Austria	FR	France	LU	Luxembourg	SN	Senegal
AU	Australia	GA	Gabon	LV	Latvia	SZ	Swaziland
AZ	Azerbaijan	GB	United Kingdom	MC	Monaco	TD	Chad
BA	Bosnia and Herzegovina	GE	Georgia	MD	Republic of Moldova	TG	Togo
BB	Barbados	GH	Ghana	MG	Madagascar	TJ	Tajikistan
BE	Belgium	GN	Guinea	MK	The former Yugoslav Republic of Macedonia	TM	Turkmenistan
BF	Burkina Faso	GR	Greece			TR	Turkey
BG	Bulgaria	HU	Hungary	ML	Mali	TT	Trinidad and Tobago
BJ	Benin	IE	Ireland	MN	Mongolia	UA	Ukraine
BR	Brazil	IL	Israel	MR	Mauritania	UG	Uganda
BY	Belarus	IS	Iceland	MW	Malawi	US	United States of America
CA	Canada	IT	Italy	MX	Mexico	UZ	Uzbekistan
CF	Central African Republic	JP	Japan	NE	Niger	VN	Viet Nam
CG	Congo	KE	Kenya	NL	Netherlands	YU	Yugoslavia
CH	Switzerland	KG	Kyrgyzstan	NO	Norway	ZW	Zimbabwe
CJ	Côte d'Ivoire	KP	Democratic People's Republic of Korea	NZ	New Zealand		
CM	Cameroon			PL	Poland		
CN	China	KR	Republic of Korea	PT	Portugal		
CU	Cuba	KZ	Kazakstan	RO	Romania		
CZ	Czech Republic	LC	Saint Lucia	RU	Russian Federation		
DE	Germany	LI	Liechtenstein	SD	Sudan		
DK	Denmark	LK	Sri Lanka	SE	Sweden		
EE	Estonia	LR	Liberia	SG	Singapore		

## COMBINED PLASMA REACTOR CATALYST SYSTEMS FOR EFFECTIVE EMISSION CONTROL OVER A RANGE OF OPERATING CONDITIONS

### BACKGROUND

5 Worldwide, there is increasing pressure to reduce petroleum usage in transportation applications. The major drivers for this are requirements to reduce the rate at which we are consuming limited supplies of fossil fuels and to reduce emissions of major greenhouse gas, carbon dioxide, CO<sub>2</sub>. A primary method to improve fuel economy and reduce CO<sub>2</sub> emissions from internal combustion engines is to operate under lean air/fuel  
10 ratio conditions. Lean burn engines, including both lean burn spark ignition and compression, i.e., diesel, engines, offer substantial benefits in improved efficiency and reduced fuel consumption and CO<sub>2</sub> emissions. A major factor limiting the widespread use of lean burn engines for transportation applications, particularly in passenger cars, is the lack of satisfactory technology for the control of tailpipe emissions, especially, emissions of  
15 oxides of nitrogen, NO<sub>x</sub>, and particulates, that contribute to localized air pollution.

Today, most spark ignition, gasoline-fueled vehicles are equipped with three-way catalysts ("TWC") for the control of hydrocarbons, HC, carbon monoxide, CO, and oxides of nitrogen emissions. Three-way catalysts are highly effective in controlling emissions engines operated at or near a stoichiometric air to fuel ratio. However, when  
20 operated under lean conditions, where excess oxygen is present in the exhaust gas mixture, three-way catalysts lose their effectiveness in controlling emissions produced by the engine.

Lean burn engines, particularly diesel engines, also produce significant quantities of particulate emissions. Particulate emissions are carbonaceous in nature, contribute significantly in atmospheric particulate pollution, and are believed to be  
25 mutagenic or carcinogenic. Therefore, a great deal of research has been directed to the development of methods for eliminating NO<sub>x</sub> and particulate emissions from lean burn engines. However, to-date, all known methods have at least one serious flaw that limits their effectiveness. The leading candidate technologies for the control of NO<sub>x</sub> in lean burn engines are selective catalytic reduction, SCR, and NO<sub>x</sub> storage and reduction, S&R, and  
30 the leading candidate technology for the control of particulates is catalytic particulate traps, typically in the form of flow through monoliths or ceramic particulate traps.

#### Selective Catalytic Reduction (SCR) with Hydrocarbons

The three-way catalysts used for emission control in motor vehicles are  
35 non-selective in the reduction of NO<sub>x</sub>. As a result, in the presence of excess oxygen, the reductants present in the exhaust, i.e., HC, CO, and H<sub>2</sub>, are preferentially oxidized by excess oxygen in the reaction:

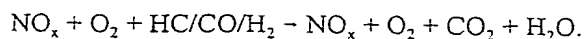

The  $\text{NO}_x$  remains unreduced, as long as excess  $\text{O}_2$  is present.

- In contrast, selective catalytic reduction (SCR) of  $\text{NO}_x$  requires a catalyst  
 5 capable of 'selectively' reacting  $\text{NO}_x$  with one or more of the reductants present in the  
 exhaust in the presence of excess oxygen in the reaction:

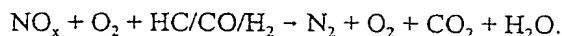

- 10 The  $\text{NO}_x$  is first preferentially, i.e., selectively, reduced to  $\text{N}_2$ . Then, only after the  $\text{NO}_x$  is  
 reduced, is the HC, CO, and/or  $\text{H}_2$  oxidized to water and carbon dioxide by the oxygen.

- In the past ten years, a great deal of work has been performed in both  
 industrial and academic laboratories on the development of catalysts for the selective  
 reduction of  $\text{NO}_x$ . See, e.g., M. Shelef, "Selective Catalytic Reduction of  $\text{NO}_x$  with N-Free  
 15 Reductants", Chem. Rev. 95, 209-225 (1994); and , A. Fritz and V. Pitchon, "The Current  
 State of Research on Automotive Lean  $\text{NO}_x$  Catalysis", Appl. Catal. B: Environ., 13, 1-25,  
 1997, the teachings of which are incorporated herein in their entirety by reference. This  
 work has resulted in the identification of a number of catalytic materials that demonstrate at  
 least some selectivity for  $\text{NO}_x$  reduction, where the selective reductant for  $\text{NO}_x$  is typically  
 20 HC in the reaction

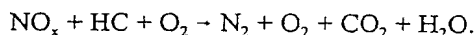

- Selective catalytic reduction catalysts can generally be placed in three  
 25 categories, precious metals, base metals supported on acidic supports, and acidic oxides.  
 Useful precious metals include platinum, Pt, palladium, Pd, rhodium, Rh, ruthenium, Ru,  
 and iridium, Ir, where Pt is generally the most active. Useful base metals include, but are  
 not limited to, copper, Cu, which is one of the most active base metals, cobalt, Co, iron, Fe,  
 germanium, Ge, and cerium, Ce, and other metals that have been shown to be active.  
 30 Useful acidic support materials for the base metal catalysts include Zeolites, which are some  
 of the most active acidic support materials available for the base metals catalysts. One of  
 the most active and most studied base metal catalyst systems is Cu/ZSM-5, where ZSM-5 is  
 a specific zeolite type. Useful acidic oxides include, but are not limited to,  $\text{Al}_2\text{O}_3$ ,  
 $\text{Al}_2\text{O}_3\text{-SiO}_2$ ,  $\text{TiO}_2$ , and  $\text{ZrO}_2$ . The unique performance characteristics of these selective  
 35 catalytic reduction selective catalytic reduction catalysts as a function of temperature is  
 illustrated in Figure 1 for Pt, Cu/ZSM-5, and solid oxides. In particular, platinum functions

as a selective reduction catalyst between about 200 and about 300°C, the Cu/ZSM-5 system functions as a selective reduction catalyst between about 300 and about 500°C, and the solid oxides, which are preferably acidic, function as selective reduction catalysts between about 500 and about 700°C.

5 For each of these catalyst systems, the NO<sub>x</sub> conversion efficiency increases with increasing temperature to a maximum level, and then declines at higher temperatures. This is in contrast to the temperature dependence of three-way catalyst systems that light-off at low temperatures and reach a maximum conversion efficiency that is maintained with increasing temperature. Therefore, with selective catalytic reduction catalyst  
10 technologies, there is a temperature 'window' of operation for maximum performance, which is generally relatively narrow, e.g. , on the order of about 100° to about 200°C, and no single catalyst technology is effective over the range of temperatures found in a vehicle exhaust. As a result, no single catalyst system has the performance characteristics needed to provide the NO<sub>x</sub> reduction required over the full range of operating conditions encountered  
15 in a vehicle.

Although many of the details concerning the mechanisms involved in selective catalytic reduction catalysts are still being studied, some generalizations can be made that aid in understanding the temperature dependence of these reactions, and also provide insight into potential methods for expanding the operating temperature range.  
20 General mechanistic aspects of the selective catalytic reduction reaction over platinum-based catalysts and Cu/zeolite and solid oxide catalyst are presented below. For example, with platinum catalysts at low temperature, under oxidizing conditions, the platinum surface is covered with oxygen that inhibits the dissociative absorption of NO. As the temperature is increased, HC react with the oxygen on the platinum surface, removing the oxygen, and  
25 leaving a catalytic metallic surface for the dissociative absorption of NO and the formation of N<sub>2</sub>. However, as the temperature is increased further, the HC continues to react with the oxygen on the platinum surface, but absorption of NO weakens, and cannot compete with oxygen absorption, resulting in a decrease in the NO<sub>x</sub> conversion efficiency.

With Cu/Zeolite and solid acid catalysts, three active catalytic sites are  
30 involved. First, NO is oxidized to NO<sub>2</sub> at Cu and Lewis acid sites, which are negatively charged Z<sup>+</sup>O<sup>-</sup> sites, in the reaction

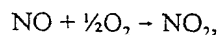

and HC are 'activated' at Bronsted acid sites, which are neutral Z<sup>-</sup>H<sup>+</sup> sites, in the reaction

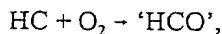

35

where the structure of HCO, the activated HC, is not well understood. The NO<sub>2</sub> is then reduced by the 'activated' HC in a reaction that forms gaseous nitrogen, carbon dioxide, and water.

Both the Cu/Zeolite and the solid acid catalysts may be categorized as multiple function catalysts in which the temperature 'window' of the catalysts results from the dual function nature of the overall catalytic reaction. The low temperature limit is controlled and determined by the catalytic activity for NO to NO<sub>2</sub> oxidation, i.e., NO light-off, and the high temperature limit is controlled and determined by the catalytic activity for hydrocarbon oxidation. In particular, at high temperatures, the hydrocarbons are oxidized by oxygen faster than they react with NO<sub>2</sub>, as illustrated in Figure 2. The narrow temperature range in which known selective catalytic reduction catalysts operate severely limits the applicability of this technology for most lean burn engines.

#### Selective Catalytic Reduction (SCR) with Ammonia

Selective catalytic reduction with ammonia is a control strategy that has been utilized for the removal of NO<sub>x</sub> emissions in stationary source applications for a number of years. See, e.g., H. Bosch, Janssen, Catal. Today, 2, 1 (1994), the teachings of which are incorporated herein in their entirety by reference. In this process, ammonia (NH<sub>3</sub>) or an ammonia precursor, such as urea or cyanuric acid, is injected into an exhaust gas stream from a combustion source. The ammonia serves as the selective reducing agent for NO<sub>x</sub>, as indicated in the following reactions:

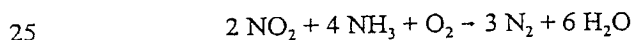
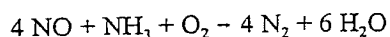

It has been proposed that selective catalytic reduction with ammonia could be utilized for the control of NO<sub>x</sub> emissions from lean burn engines utilized for mobile applications. A number of materials are known to catalyze the selective reduction reaction with ammonia including platinum group metals, base metals, and solid oxides. Some of the most effective catalysts for this reaction are Pt, vanadia (V<sub>2</sub>O<sub>5</sub>), tungsten oxide (WO<sub>3</sub>), and titania (TiO<sub>2</sub>). The temperature performance characteristics for these catalysts are similar to those discussed above for the selective catalytic reaction with hydrocarbons. For each of the catalyst systems there is a temperature window of operation for maximum performance which is relatively narrow, i.e., on the order of 100-200°C. For Pt this window is approximately 150-250°C, for V<sub>2</sub>O<sub>5</sub> and WO<sub>3</sub>, this window is approximately 300-500°C,

and for  $\text{TiO}_2$  it is above  $500^\circ\text{C}$ . The high temperature limit for these catalysts is the temperature at which rapid oxidation of ammonia occurs, thus removing from the reaction mixture before it can reduce  $\text{NO}_x$ . Thus, as is found for the selective catalytic reduction with hydrocarbons, there is not a single catalyst system for the selective reduction with ammonia that spans the full range of operating temperatures seen in vehicle exhaust.

In addition to its narrow temperature window of operation, Pt catalysts have the further disadvantage in vehicle applications of catalyzing the oxidation of  $\text{SO}_2$  to  $\text{SO}_3$ . The  $\text{SO}_3$  then reacts with water in the exhaust to form sulfuric acid ( $\text{H}_2\text{SO}_4$ ), which is emitted from the tailpipe as particulate emissions. Moreover, in order to effectively utilize base metal catalysts such as  $\text{V}_2\text{O}_5$  and  $\text{WO}_3$  in this application, a method that lowers the effective operating temperature of the selective reduction is required. One potential method is the conversion of  $\text{NO}$  to  $\text{NO}_2$  before the exhaust gas reaches the active catalyst. It is known that the reaction of  $\text{NO}_2$  with  $\text{NH}_3$  occurs at lower temperatures than the reaction of  $\text{NO}$  with  $\text{NH}_3$  over these base metal catalyst systems. This could lower the effective operating temperature of the base metal catalysts, and would allow effective application to  $\text{NO}_x$  removal in lean burn vehicle exhaust.

#### $\text{NO}_x$ Storage and Reduction (S&R)

In addition to a catalyst,  $\text{NO}_x$  storage and reduction (S&R) requires an engine control strategy. Prior art  $\text{NO}_x$  storage and reduction are described in W. Brogner, M. Kramer, B. Krutzsch, S. Pischinger, D. Voigtander, G. Wenninger, F. Wirbeleit, M.S. Brogan, R.J. Brisley, and D.E. Webster, "Removal of nitrogen oxides from the exhaust of a lean-tune gasoline engine", Appl. Catal. B: Environ., 7, 153-171, 1995, J.S. Hepburn, E. Thanasiu, D.A. Dobson, and W.L. Watkins, "Experimental and Modeling Investigations of  $\text{NO}_x$  Trap Performance", SAE Technical Paper 962051, San Antonio, TX October 14-17, 1996, the teachings of which are incorporated herein in their entirety by reference.

A typical catalyst used for  $\text{NO}_x$  reduction is a platinum/rhodium (Pt/Rh) three-way catalyst formulation that has been modified by the addition of a component that forms a stable nitrate under lean conditions. The additional component is typically barium, Ba, but other alkaline metals and alkaline earth elements have been explored, including lithium, Li, sodium, Na, potassium, K, rubidium, Rb, cesium, Cs, magnesium, Mg, calcium, Ca, and strontium, Sr. The  $\text{NO}_x$  storage components and the three-way catalyst components are at or near the same catalyst surface.

To control  $\text{NO}_x$  under lean conditions,  $\text{NO}$  is oxidized over platinum to form  $\text{NO}_2$ , which then reacts with the alkaline or alkaline earth oxide to form a metal nitrate by the lean storage reaction:

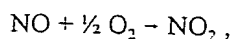

followed by the formation of a metal nitrate in the reaction

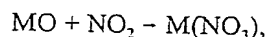

where M is one of the metals listed above. These reactions are not catalytic reactions, but, instead, can be thought of as reactions for the removal of  $\text{NO}_x$  by titration with the metal oxide.  $\text{NO}_x$  removal efficiencies greater than about 80 percent can be achieved as long as metal oxide is available for the reaction. At the point that the metal oxide is exhausted,  $\text{NO}_x$  'breaks-through' the catalyst, and is emitted out the tailpipe. To avoid  $\text{NO}_x$  break-through, and to regenerate the metal oxide, an engine control strategy is employed that periodically switches the engine from lean to stoichiometric or slightly rich operation. Under stoichiometric or rich conditions, the metal nitrate decomposes, and the  $\text{NO}_x$  is released from the catalyst surface and reduced to  $\text{N}_2$  by the normal action of the three-way catalyst.

In the rich reduction reactions, the metal nitrate first decomposes, regenerating the metal oxide, and releasing NO and carbon dioxide through the reaction

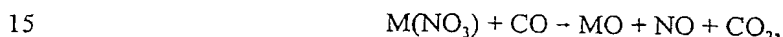

and the NO is then removed catalytically in the reaction

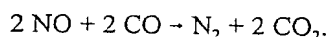

Typically, the storage capacity of the catalyst requires an engine control strategy with a periodicity of approximately 60 seconds lean and 10 seconds rich. However, this typically degrades the smoothness and drivability of the engine.

As discussed above,  $\text{NO}_x$  storage and reduction catalysts have demonstrated high  $\text{NO}_x$  removal efficiencies of at least about 80 percent, and are presently leading candidates for  $\text{NO}_x$  control of lean burn engines. However, major problems exist with the storage and reduction approach, including the added complexity and potential drivability issues associated with the low frequency air/fuel perturbations, the loss in fuel economy benefit due to the amount of time operating under stoichiometric or rich conditions, and the extreme sensitivity of  $\text{NO}_x$  storage components to sulfur poisoning. This sulfur poisoning occurs because alkaline and alkaline earth metals typically form more stable sulfates than nitrates under lean conditions, i.e., in the presence of excess oxygen, where the sulfates are formed by oxidation of  $\text{SO}_2$  to  $\text{SO}_3$  in the reaction

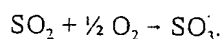

The  $\text{SO}_3$  produced then reacts with the metal oxide to form the sulfate in the reaction

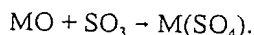

Platinum, which is typically used in  $\text{NO}_x$  storage and reduction catalyst formulations due to its high activity for NO oxidation, is the most active catalyst known for  $\text{SO}_2$  oxidation, forming  $\text{SO}_3$  when  $\text{SO}_2$  is present in the exhaust,  $\text{SO}_3$ . As a result, in the



presence of SO<sub>2</sub>, a metal sulfate is formed rather than the desired metal nitrate, and the equilibrium in the reaction

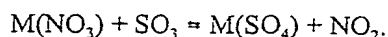

lies far to the right as described in X. Xue, K. Seshan, and J.R.H. Ross, "Roles of supports, Pt loading and Pt dispersion in the oxidation of NO to NO<sub>2</sub> and of SO<sub>2</sub> to SO<sub>3</sub>", Appl. Catal. B: Environ., 11, 65-79, 1996, the teachings of which are incorporated herein in their entirety by reference.

The formation of the stable sulfate species effectively inhibits NO<sub>x</sub> storage, and, thus, using prior art methods, dramatic reductions in fuel sulfur levels are required for the effective implementation of this technology. Automotive manufacturers have stated that gasoline with 10 ppm, or less, sulfur will be required for adoption of this technology, and, as gasoline with such a low sulfur level is not widely available, a system or process that could reduce or eliminate this sulfur sensitivity would be of great significance.

In lean burn engines in general, and diesels in particular, control of particulate is generally achieved by catalytic trap oxidation. Where only modest reductions in particulates of no more than about 30 percent are required, a standard flow-through monolithic catalyst can be utilized in which particulates diffuse to the catalyst surface, and are absorbed and oxidized on the surface. However, if higher particulate removal rates are required, a filtering system must be used. Typically, known filters in such systems are generally ceramic, providing particulate removal rates of up to about 80 percent, but require frequent, if not continuous, regeneration by oxidation of the particulates to avoid blocking the filter, which will otherwise result in a large back pressure build up. However, the oxidation of particulates by oxygen is only effective at temperatures above about 350° to about 400°C, which is significantly higher than the low gas temperatures typically found in diesel engine exhaust gases. As a result, oxidation of the particulates is not always possible with diesel engine exhaust gas, and auxiliary heating systems or engine management modifications are required to provide the required exhaust temperatures either continuously or at frequent intervals. Such systems, which have durability problems, add considerable complexity and expense to the emission control system.

An alternative low-temperature particulate oxidation reaction that involves NO<sub>2</sub> as an oxidant exists is disclosed in B.J. Cooper and J.E. Thoss, "The Role of NO in Diesel Particulate Emission Control", SAE Technical Paper No. 890404, 1989, the teachings of which are incorporated herein in their entirety by reference. The low-temperature reaction becomes effective at a temperature of only about 200° to about 250°C, and, thus, if the low temperature reaction is utilized, auxiliary heating of the particulate trap will not be required in a diesel engine. However, these systems are not in

widespread use, because, as discussed above, the platinum required for oxidation of NO to NO<sub>2</sub> is also very active for SO<sub>2</sub> to SO<sub>3</sub> oxidation. Thus, where significant quantities of sulfur typically are present, such as in the diesel fuel, SO<sub>2</sub> is oxidized to SO<sub>3</sub>, which reacts with water to form sulfuric acid, H<sub>2</sub>SO<sub>4</sub>, which is emitted from the tailpipe as a particulate, potentially resulting in a net increase in particulate emissions from the engines rather than a net decrease.

Therefore, before the technologies discussed above can be effectively implemented for the reduction of emissions from lean burn engines, several key technological problems that must be overcome. In particular, for selective catalytic reduction catalysts with hydrocarbon or ammonia, the temperature 'window' of operation and the overall NO<sub>x</sub> reduction performance must be increased. This requires a catalyst or reactor system that is capable of oxidizing NO to NO<sub>2</sub> at low temperatures, i.e., lower than the temperature at which hydrocarbons are oxidized. Similarly, NO<sub>x</sub> storage and reduction and catalytic particulate traps presently require a platinum based catalyst, which efficiently oxidizes NO to NO<sub>2</sub> at low temperatures, but also oxidizes SO<sub>2</sub> to SO<sub>3</sub> with even greater efficiency. Therefore, where sulfur is present in the fuel, the formation of SO<sub>3</sub> results in the blocking of NO<sub>x</sub> storage sites due to formation of sulfates that are thermodynamically more stable than the nitrates in NO<sub>x</sub> storage and reduction systems, and, in catalytic particulate traps, SO<sub>3</sub> is converted to sulfuric acid, which is released from the tailpipe as particulates.

Therefore, a need remains for a device and a method to oxidize NO to NO<sub>2</sub> without oxidizing SO<sub>2</sub> to SO<sub>3</sub> in NO<sub>x</sub> storage and reduction, which would provide much improved NO<sub>x</sub> removal performance without the effects of SO<sub>3</sub> blocking of NO<sub>x</sub> storage sites, and in catalytic particulate traps, which would provide a supply of NO<sub>2</sub> for the continuous oxidation and removal of particulate without increasing the formation of H<sub>2</sub>SO<sub>4</sub> particulate emissions. The present invention provides such a device and method.

#### SUMMARY OF THE INVENTION

The present invention is directed to an apparatus and a method for removing at least a portion of at least one pollutant in an exhaust gas stream containing exhaust gas formed from the combustion of fuel in an engine, which may be any type of internal or external combustion engine, but is preferably a lean burn spark ignition engine, a compression ignition engine, such as a diesel engine, or a turbine engine. The apparatus comprises at least one device for removing at least a portion of at least one of oxides of nitrogen, hydrocarbons, carbon monoxide, and particulates in the exhaust gas and a device for producing a non-thermal plasma in at least a portion of the exhaust gas stream. The one device for removing at least a portion of at least one of oxides of nitrogen, hydrocarbons,

carbon monoxide, and particulates in the exhaust gas, which is positioned such that at least a portion of the exhaust gas stream from the engine passes through the device, has an inlet and an outlet, and is preferably one of selective catalytic reduction catalysts, particulate traps, selective catalytic reduction catalyst coated particulate traps, oxide of nitrogen storage and reduction catalysts, oxidation catalysts, and three-way catalysts. At least a portion of the exhaust gas stream is exposed to the non-thermal plasma that is formed in or by a non-thermal reactor, and at least a portion of that portion of the exhaust gas stream exposed to the non-thermal plasma is introduced into the exhaust gas stream at a point upstream of or at the at least one device for removing at least one of oxides of nitrogen, hydrocarbons, carbon monoxide, and particulates. Preferably, at least a portion of the non-thermal plasma is positioned within the exhaust gas stream upstream of or at the at least one device for removing at least a portion of at least one of oxides of nitrogen, hydrocarbons, carbon monoxide, and particulates in the exhaust gas.

The apparatus of the invention may further comprise at least one additional device for removing at least a portion of at least one of oxides of nitrogen, hydrocarbons, carbon monoxide, and particulates in the exhaust gas. As with the first device, the second device has an inlet and an outlet, and is preferably selected from the group consisting of selective catalytic reduction catalysts, particulate traps, selective catalytic reduction catalyst coated particulate traps, oxide of nitrogen storage and reduction catalysts, oxidation catalysts, and three-way catalysts. The second device is typically positioned such that at least a portion of the exhaust gas stream from the engine, which has been exposed to the non-thermal plasma, passes through the second device after first passing through the first device for removing at least a portion of at least one of oxides of nitrogen, hydrocarbons, carbon monoxide, and particulates in the exhaust gas.

Preferably the device for producing a non-thermal plasma in the exhaust gas or non-thermal reactor comprises a corona discharge device. A corona discharge device useful in the invention typically comprises at least one first electrode, at least one second electrode positioned a distance from the first electrode, and dielectric material positioned between the first electrode and the second electrode. The corona discharge device may be attached by means of threads to the side of the exhaust pipe or to the at least one device for removing at least a portion of at least one of oxides of nitrogen, hydrocarbons, carbon monoxide, and particulates in the exhaust gas. Preferably, the corona discharge device is powered by a high frequency power supply having an operational frequency of at least about 1,000 Hz adapted to provide electrical power to the corona discharge device, and requires no more than about 0.1 percent, more preferably, no more than about .01 percent, of the rated power output of the engine.

Preferably, the apparatus further comprises an exhaust pipe attached to the inlet of the at least one at least one device for removing at least one of oxides of nitrogen, hydrocarbons, carbon monoxide, and particulates, such that at least a portion of the exhaust gas stream passes through the exhaust pipe to and through the at least one at least one  
5 device for removing at least one of oxides of nitrogen, hydrocarbons, carbon monoxide, and particulates, wherein the exhaust pipe comprises a fitting for positioning the device for producing a non-thermal plasma in the exhaust stream or a portion thereof, so that a non-thermal plasma is produced in the exhaust stream upstream of or at the at least one at least one  
10 device for removing at least one of oxides of nitrogen, hydrocarbons, carbon monoxide, and particulates.

Where the at least one device for removing at least one of oxides of nitrogen, hydrocarbons, carbon monoxide, and particulates is a selective catalytic reduction catalyst, the non-thermal plasma and selective catalytic reduction catalyst may be configured to provide an operational range of at least about 500°C. The non-thermal plasma is preferably  
15 positioned within the exhaust gas stream upstream of or at the selective catalytic reduction catalyst, which, preferably, reduces oxides of nitrogen with at least one of hydrocarbons and ammonia, which may exist naturally in the exhaust gas stream, or the apparatus may be configured and adapted for injecting at least one of hydrocarbons and ammonia into the exhaust gas stream upstream of or at the selective reduction catalyst.

20 Useful selective catalytic reduction catalyst include, but are not limited to, precious metals, base metals on acidic supports, and solid oxides. Preferably, the base metals may have acidic supports, the solid oxides are acidic, the precious metal is platinum, the base metal is copper, and the acid support is a zeolite.

Using a selective reduction catalyst, the apparatus oxidizes NO to NO<sub>2</sub>  
25 within the non-thermal plasma at a first lower temperatures, and oxidizes at least one oxidizable material in the exhaust gas stream, such as hydrocarbons and ammonia, with oxygen at a second higher temperature. Typically, the first lower temperature is about 100°C, and the second higher temperature is at least about 500°C, but is preferably at least about 700°C.

30 The method of the invention comprises removing at least a portion of at least one pollutant in an exhaust gas stream containing exhaust gas formed from the combustion of fuel in an engine, which is preferably one of a lean burn spark ignition engine, a compression ignition engine, such as a diesel, or a turbine engine, and is preferably continuously operated in lean burn mode, but may be periodically operated on a  
35 stoichiometric or rich fuel mixture, e.g., when the engine is under a load that requires a increased power output, and on a lean fuel mixture when the engine is under a reduced load.

The method comprises exposing at least a portion of the exhaust gas stream to a non-thermal plasma, and passing at least a portion of the exhaust gas stream that has been passed through the non-thermal plasma through at least one device for removing at least a portion of at least one of oxides of nitrogen, hydrocarbons, carbon monoxide, and  
5 particulates in the exhaust gas, where the device has an inlet and an outlet, and is typically one of a selective catalytic reduction catalyst, particulate trap, selective catalytic reduction catalyst coated particulate traps, oxide of nitrogen storage and reduction catalyst, oxidation catalyst, or three-way catalyst. The non-thermal plasma may be positioned directly within the exhaust gas stream upstream of or at the device for removing oxides of nitrogen or  
10 particulates. In the alternative, a remote non-thermal reactor may be used in which a portion of the exhaust gas stream is separated from the rest of the exhaust gas stream, and then exposed to the non-thermal plasma. The portion of the exhaust gas stream exposed to the non-thermal plasma is then introduced into the exhaust gas stream upstream of or at the device for removing at least one of the oxides of nitrogen, hydrocarbons, carbon monoxide,  
15 and particulates.

The exhaust gas stream may be passed through at least two devices device for removing at least a portion of at least one of oxides of nitrogen, hydrocarbons, carbon monoxide, and particulates in the exhaust gas, where each device is of the type discussed above, such that the exhaust gas stream passes through the first device before passing  
20 through the second device.

The method of the invention preferably comprises producing the non-thermal plasma using a corona discharge device, which comprises a first electrode, a second electrode positioned a distance from the first electrode, and a dielectric material positioned between the first electrode and the second electrode, which is used to oxidize NO in the  
25 exhaust stream to NO<sub>2</sub>, preferably at a temperature of about 100°C.

Where a selective catalytic reduction catalyst is used as the at least one device for removing at least a portion of at least one of oxides of nitrogen, hydrocarbons, carbon monoxide, and particulates in the exhaust gas, an oxidation catalyst, a particulate trap, an oxidation catalyst, or a three-way catalyst may also be positioned downstream of  
30 the selective reduction catalyst. This allows the further removal of particulates, residual hydrocarbons and carbon monoxide, or residual hydrocarbons, carbon monoxide, and oxides of nitrogen from the exhaust gas stream depending on the device used.

In the method of the invention, NO in the exhaust gas stream is first oxidized to NO<sub>2</sub> with the non-thermal plasma, and NO<sub>x</sub> in the exhaust gas stream is then reduced to  
35 N<sub>2</sub> by contacting the exhaust gas stream containing the NO<sub>2</sub> formed by oxidizing NO with the selective reduction catalyst. Reduction of the NO<sub>x</sub> may be facilitated by contacting the

NO<sub>2</sub> with at least one of hydrocarbons or ammonia on the selective reduction catalyst. Oxidizable compounds, such as hydrocarbons and ammonia, may be oxidized with the selective reduction catalyst at a temperature of at least about 500°C, preferably at a temperature of at least about 700°C.

5                   The NO<sub>2</sub> produced in the non-thermal plasma may be used to enhance the oxidation of particulates trapped in a particulate trap. The NO<sub>2</sub> may be generated continuously or on an as needed basis to avoid blocking the particulate trap, where the blocking would result in a build-up of back pressure.

                  An oxide of nitrogen storage and reduction catalyst may be used in the  
10 invention, such that oxides of nitrogen stored on the nitrogen storage and reduction catalyst surface during lean burn operation of the engine, and released during periodic operation of the engine on a stoichiometric or rich air fuel mixture, releasing the oxides of nitrogen from the catalyst surface, which is then reduced to N<sub>2</sub>.

#### 15                   **BRIEF DESCRIPTION OF THE DRAWINGS**

                  Figure 1 illustrates the NO<sub>x</sub> conversion efficiency as a function of temperature for different selective catalytic reduction catalyst types.

                  Figure 2 illustrates the temperature dependence of selective catalytic reduction catalysts.

20                   Figure 3 illustrates the temperature window of a combined non-thermal plasma/catalytic selective catalytic reduction reactor.

                  Figure 4 is a schematic of an exhaust system incorporating a remote non-thermal plasma reactor.

                  Figure 5 illustrates a corona discharge device mounted in an exhaust shunt;

25                   Figure 6 illustrates a corona discharge device having concentric electrodes and a dielectric coated inner electrode;

                  Figure 7 illustrates a corona discharge device having concentric electrodes and a dielectric coated outer electrode;

                  Figure 8 illustrates a distant ground corona discharge device;

30                   Figure 9 illustrates a corona discharge device of the type depicted in Fig. 5 equipped with a flame arrester;

                  Figure 10 illustrates a compact corona discharge device;

                  Figure 11 illustrates a compact corona discharge device having an extended skirt;

35                   Figure 12 illustrates a compact corona discharge device equipped with an orifice for injecting air;

Figure 13 illustrates a corona discharge device mounted in a manner that takes advantage of the pumping action of pressure variations in the exhaust gas stream;

Figure 14 illustrates a corona discharge device mounted in conjunction with a plenum that augments the pumping action of pressure variations in the exhaust gas stream;

5 Figure 15 is a cross section of a preferred embodiment of the corona discharge device of the invention;

Figure 16 illustrates a corona discharge device having slots for the exchange of gas between the non-thermal plasma and the gas stream;

10 Figure 17 illustrate a corona discharge device having dielectric material adjacent to both the inner electrode and the inner surface of outer electrode;

Figure 18 illustrates an outer electrode having louvers to enhance the exchange of gas;

Figure 19 illustrates a cold start gas diverter;

Figure 20 illustrates a cold start gas diverter used with an exhaust gas shunt;

15 Figure 21 illustrates a corona discharge device having a high voltage electrode with a circular end;

Figure 22 illustrates a corona discharge device of the type shown in Figure 21 that minimizes arc breakdown.

20 Figure 23 illustrates the invention as used with an internal combustion engine.

### **DETAILED DESCRIPTION OF THE INVENTION**

25 As used herein, the term "lean burn engine" refers to any engine that for a significant portion of its operation operates on a lean air/fuel mixture, i.e., an air/fuel mixture in which the amount of air is greater than that required to provide the stoichiometric amount of oxygen required to oxidize all of the fuel in the mixture.

30 In addition, as used herein, the term "particulates" refers to particulate matter produced during combustion. Particulates are particularly made up of carbon, but may also include heavy hydrocarbons.

The present invention is directed to a combined non-thermal plasma/catalytic reactor system that overcomes the shortcomings of prior art selective catalytic reduction systems, particulate traps, and NO<sub>x</sub> storage and reduction systems for the effective control of emissions from compression ignition, i.e., diesel, and spark ignition lean burn engines.  
35 Typically, the non-thermal plasma is a corona discharge that is produced by a corona discharge device. A preferred embodiment of the corona discharge device is a low power

unit requiring no more than 0.1, and, more preferably, no more than 0.01 percent of the rated power of the engine during normal operation, *i.e.*, about 15 to about 150 Watts for a 200 horsepower engine, where the device and power supply are designed for operation at high powers, *i.e.*, up to about 300 Watts, for brief period of time. However, as will be  
5 recognized by those of ordinary skill in the art, in certain applications, higher power may be required.

In the combined non-thermal plasma/catalytic reactor of the invention, gas phase reactions are initiated by a non-thermal plasma prior to contact of the gas mixture with a catalyst surface, *e.g.*, in an exhaust gas stream up stream of or at a catalyst. The  
10 non-thermal plasma/catalytic reactor may be simply be a section of exhaust pipe after a corona discharge unit, where gas phase reactions occurs prior to entering a device for removing at least one of oxides of nitrogen, hydrocarbons, carbon monoxide, and particulates. However, typically, the non-thermal plasma/catalytic reactor is a specifically  
15 designed gas phase reactor positioned prior to inlet of the device for removing at least one of oxides of nitrogen, hydrocarbons, carbon monoxide, and particulates, or incorporated within the device for removing at least one of oxides of nitrogen, hydrocarbons, carbon monoxide, and particulates. It has been discovered that non-thermal plasma reactors,  
operating within a gas mixture containing hydrocarbons and excess oxygen, such as, *e.g.*, the exhaust gas produced by a diesel engine or a spark ignition lean burn engine, effectively  
20 convert NO to NO<sub>2</sub> with modest energy densities without oxidizing SO<sub>2</sub> to SO<sub>3</sub>. As such, the combined non-thermal plasma/catalytic reactor of the invention provides a significant advance in lean burn emission control.

As discussed above, increasing the width of a selective catalytic reduction reactor temperature window to improve the reactor performance, requires a combination of  
25 low temperature oxidation of NO to NO<sub>2</sub> with a catalyst that oxidizes only hydrocarbons or ammonia at higher temperatures. The combined non-thermal plasma/catalytic reactor of the invention provides non-thermal plasma is capable of initiating oxidation of NO to NO<sub>2</sub> at temperatures less than about 100°C, which is then followed by the high temperature oxidation of hydrocarbons or ammonia, typically with a solid oxide catalyst that only  
30 oxidizes hydrocarbons and ammonia at higher temperature to provide a temperature window as indicated in Figure 3. The non-thermal plasma used to initiate the oxidation is preferably produced with a corona discharge device of the type disclosed in co-pending U.S. Patent Application No. 09/468,059, filed December 17, 1999, which is a continuation of U.S. Patent Application No. 08/947,287, filed October 7, 1997, now U.S. Patent No.  
35 6,xxx,xxx, as well as in co-pending U.S. Patent No. 09/122,394, filed July 24, 1998, which is a continuation-in-part of U.S. Patent Application No. 08/947,287, and in provisional U.S.



Patent Nos. 60/121,903 and 60/142,318, filed February 26, 1999, and July 2, 1999, respectively, the teachings of which are incorporated herein in their entirety by reference. Examples of corona discharge devices useful for forming a non-thermal plasma in the combined non-thermal plasma/catalytic reactor of the invention are described below.

5           The formation of a non-thermal plasma in the combined non-thermal plasma/catalytic reactor of the invention provides a reactor system having a larger temperature window, typically, of about 300 to about 400°C wide, in contrast to present selective catalytic reduction catalyst systems having temperature windows with a width of only about 100 to about 200°C. In addition, the combined non-thermal plasma/catalytic  
10 reactor substantially increases peak NO<sub>x</sub> conversion efficiency as a result of this wider window of operation.

As discussed above, both NO<sub>x</sub> storage and reduction and particulate trap systems utilize platinum in the catalyst formulations for its high NO oxidation activity. Unfortunately, platinum is also very active in the oxidation of SO<sub>2</sub>, leading to sulfur  
15 poisoning and/or sulfuric acid emissions. However, utilization of the non-thermal plasma reactor of the invention to oxidize NO to NO<sub>2</sub> without the oxidation of SO<sub>2</sub> to SO<sub>3</sub> eliminates or greatly reduces the oxidation of SO<sub>2</sub>. In the case of NO<sub>x</sub> storage and reduction, this also allows the use of Pd/Rh catalysts that offer advantages in performance and durability.

20           Various embodiments of the non-thermal plasma/catalytic reactor system of the invention are useful for improving emission control in lean burn engines. In each embodiment, the reactor comprises a non-thermal plasma source in a gas phase reactor for efficient NO to NO<sub>2</sub> oxidation, where the reactor may simply be a section of tailpipe containing a non-thermal plasma source, such as a corona discharge device, or a specially  
25 designed reactor much like an empty catalytic convertor, followed by one or more device for removing at least one of oxides of nitrogen, hydrocarbons, carbon monoxide, and particulates. Moreover, the electrical power consumption of the non-thermal plasma reactor can be sized to the lean capability needed for each vehicle model. The power consumption of the non-thermal plasma reactor can also be programmable to be different  
30 for each load level over the lean operating range of the vehicle. With this approach, only the needed electrical power will be drawn from the vehicle electrical system. The non-thermal plasma can also be programmed to be "off" when the vehicle is in stoichiometric operation, or to operate at the appropriate power level needed to achieve the benefits (such as sulfur tolerance or emissions (HC, CO, NO<sub>x</sub>) reductions) seen for  
35 stoichiometric air/fuel mixtures. These benefits may require less power to the non-thermal plasma than the lean operation NO<sub>x</sub> reduction requires.

As discussed above, one embodiment of the present invention is directed to an apparatus and a method for removing at least a portion of at least one pollutant, particularly oxides of nitrogen, hydrocarbons, carbon monoxide, and particulates, in an exhaust gas stream containing exhaust gas formed from the combustion of fuel in a lean burn engine. The apparatus of the invention comprises at least one device for removing at least a portion of at least one of oxides of nitrogen, hydrocarbons, carbon monoxide, and particulates in the exhaust gas and at least one device for producing a non-thermal plasma in the exhaust gas, i.e., a non-thermal plasma reactor. The device for removing at least a portion of at least one of oxides of nitrogen, hydrocarbons, carbon monoxide, and particulates in the exhaust gas has an inlet and an outlet, and is selected from the group consisting of selective catalytic reduction catalysts, particulate traps, selective catalytic reduction catalyst coated particulate traps, oxide of nitrogen storage and reduction catalysts, oxidation catalysts, and three-way catalysts. At least a portion of the exhaust gas stream is exposed to the non-thermal plasma, and at least a portion of that portion of the exhaust gas stream exposed to the non-thermal plasma is introduced into the exhaust gas stream at a point upstream of or at the at least one device for removing at least a portion of at least one of oxides of nitrogen, hydrocarbons, carbon monoxide, and particulates in the exhaust gas, such that at least a portion of the exhaust gas stream from the lean burn engine passes through the device after being exposed to the non-thermal plasma. Various useful embodiments of the invention are described below.

Reactor systems of the invention include those comprising a non-thermal plasma positioned upstream or at a selective catalytic reduction catalyst. In that embodiment, exhaust from a lean burn combustion source is first contacted with a non-thermal plasma, where NO is oxidized to NO<sub>2</sub> in the non-thermal plasma reactor. The treated exhaust gas stream is then contacted with a selective catalytic reduction catalyst, resulting in the reduction of NO<sub>x</sub> to N<sub>2</sub>. Preferably, NO<sub>2</sub> produced by exposure of the exhaust gas stream to the non-thermal plasma reactor is reduced to N<sub>2</sub> on contact with hydrocarbons ("HC") or ammonia on the surface of the selective catalytic reduction catalyst. The hydrocarbons and ammonia may be those found in the exhaust gas stream, or at least one of additional hydrocarbons or ammonia may be injected into the exhaust gas stream upstream of or at the selective catalytic reduction catalyst.

In the reactor and the process of the invention, the oxidation of NO to NO<sub>2</sub> in the non-thermal plasma occurs effectively at low temperatures, i.e., temperatures of less than about 100°C. Typically, the selective catalytic reduction catalyst does not oxidize hydrocarbons or ammonia with oxygen until significantly higher temperatures, i.e., greater

than above 500°C, and, preferably, greater than about 700°C, thereby providing a wider temperature window for the removal of oxides of nitrogen.

The sizing of the non-thermal plasma reactor and selective catalytic reduction catalyst for a particular vehicle application will depend on the engine conditions where lean operation is desired. The capacity required for the non-thermal plasma reactor and the selective catalytic reduction catalyst may be less during occasional lean cruise operation than that required during more extensive lean operation that includes higher loads and exhaust flows than the limited cruise operation. The use of this lean-run capability, measured in power to the non-thermal plasma or size of catalyst, can be optimized to provide the automaker with the lean operation and associated fuel economy improvement desired for each model of vehicle.

As noted above, the use of a non-thermal plasma reactor for low temperatures oxidation of NO to NO<sub>2</sub> combined with a high temperature selective catalytic reduction catalyst results in a wide temperature window of operation for reduction of oxides of nitrogen, typically, at least about 500°C, as well as more efficient reduction of oxides of nitrogen than present systems with selective catalytic reduction alone provide.

In a further embodiment of the invention, a non-thermal plasma reactor is used in combination with a particulate trap, and is preferably positioned in the exhaust gas stream upstream or at the particulate trap. Typically, in this embodiment, exhaust from a lean burn combustion source is first contacted with a non-thermal plasma in a non-thermal plasma reactor, and then contacted with a particulate trap resulting in the removal of particulates. Again, NO is oxidized to NO<sub>2</sub> in the non-thermal plasma, and the NO<sub>2</sub> produced in the non-thermal plasma reactor is allowed to contact particulates on or in the particulate trap, typically on the surface of the trap, resulting in oxidation of the particulates. As with the embodiment discussed above, and those discussed below, oxidation of NO to NO<sub>2</sub> effectively occurs at temperatures of less than about 100°C. As the oxidation of NO occurs at low exhaust temperatures, highly active oxidation catalysts are not required to form NO<sub>2</sub>, and, thus, the oxidation of SO<sub>2</sub> to SO<sub>3</sub> is avoided, reducing particulate emissions of the sulfuric acid, i.e., H<sub>2</sub>SO<sub>4</sub>, produced in prior art particulate trap systems. The NO<sub>2</sub> produced oxidizes particulates in the trap at low temperatures, and, thus, plugging of the trap and the build-up of back pressure in the exhaust stream is avoided. Because particulates are effectively removed by oxidation on the trap surface at low temperatures, there is no need for externally controlled trap regeneration, such as trap heaters that are used in many prior art particulate traps.

Where required by the operational conditions of the engine, the operation of the non-thermal plasma may be substantially continuous. However, where continuous

operation is not required, the operation of the non-thermal plasma may be periodic, either on an as needed basis or at specific timed intervals.

A non-thermal plasma reactor may also be used in combination with a selective catalytic reduction coated particulate trap, where the non-thermal plasma is typically positioned upstream or at the inlet of a selective catalytic reduction coated particulate trap. Again, exhaust from a lean burn combustion source is first contacted with a non-thermal plasma reactor. The treated exhaust in which NO has been oxidized to NO<sub>2</sub> is then made to come in contact with a selective catalytic reduction coated particulate trap, resulting in the efficient removal of both particulates and oxides of nitrogen. As a result, the use of a selective reduction catalyst coated particulate trap provides the benefits of both an oxidation particulate trap and a selective reduction catalyst, and provides a wide temperature window for the efficient removal of oxides of nitrogen and the continuous removal and oxidation of particulates.

A non-thermal plasma reactor may also be used in combination with an oxides of nitrogen storage and reduction catalyst, where the non-thermal plasma is typically positioned upstream of or at the oxides of nitrogen storage and reduction catalyst. Again, exhaust from a lean burn combustion source is first contacted with a non-thermal plasma reactor, where NO is oxidized to NO<sub>2</sub> in the non-thermal plasma. The exhaust gas stream containing NO<sub>2</sub> is then made to come in contact with an oxides of nitrogen storage and reduction catalyst, where the NO<sub>2</sub> is stored on the oxides of nitrogen storage and reduction catalyst. The engine or combustion source may be operated on a lean air/fuel mixture substantially continuously, or may be periodically switched from lean to a stoichiometric or rich air/fuel mixture. Under lean conditions, NO<sub>2</sub> formed in the non-thermal plasma reactor is stored on the oxides of nitrogen storage and reduction catalyst. Then, under stoichiometric or rich conditions, the NO<sub>2</sub> is released from the surface of the catalyst and reduced by normal three-way catalysis to N<sub>2</sub>.

The conversion of NO to NO<sub>2</sub> in the non-thermal plasma reactor occurs without formation of SO<sub>3</sub>, thereby avoiding the formation of stable sulfates at the oxides of nitrogen storage sites of the oxides of nitrogen storage and reduction catalyst and the resulting sulfur poisoning of the catalyst. As the conversion of NO to NO<sub>2</sub> occurs in the non-thermal plasma, no platinum is required in the oxides of nitrogen storage and release catalyst. As a result of the use of non-platinum catalysts, thermal stability is improved, and higher catalytic activity is achieved. Moreover, the sulfur poisoning found with platinum based oxides of nitrogen storage and reduction technologies is also avoided.

A non-thermal plasma reactor may also be used in combination with more than one device for the removal of at least one oxides of nitrogen, hydrocarbons, carbon

monoxide, and particulates, e.g., the use of a thermal plasma in combination with a selective reduction catalytic and an oxidation catalyst. Typically, the non-thermal plasma is positioned upstream of a selective catalytic reduction catalyst that upstream of an oxidation catalyst, which removes residual hydrocarbons and carbon monoxide from the exhaust gas stream following treatment with the selective catalytic reduction catalyst.

A non-thermal plasma reactor may also be used in combination with a selective catalytic reduction coated particulate trap and an oxidation catalyst. Typically, a non-thermal plasma is positioned upstream of or at the inlet of a selective catalytic reduction coated particulate trap that is upstream of an oxidation catalyst. Such as system removes oxides of nitrogen, hydrocarbons, carbon monoxide, and particulates with the particulate trap, and the oxidation catalyst removes residual oxidizable species, such as hydrocarbons and carbon monoxide.

A non-thermal plasma reactor may also be used in combination with a selective catalytic reduction catalyst and a three-way catalyst. Typically, a non-thermal plasma is positioned upstream of or at a selective catalytic reduction catalyst that is upstream of a three-way catalyst, that may be of the type currently used on most passenger cars and light trucks. The exhaust from a lean burn combustion source is first passed through a non-thermal plasma, and is then made to come in contact with a selective catalytic reduction catalyst. The output of the selective reduction catalyst is then passed through a conventional three-way catalyst. Such a system allows engine operation at both stoichiometric and lean conditions without a decrease in the ability to remove oxides of nitrogen. During operation with a stoichiometric air/fuel mixture, the three-way catalyst removes hydrocarbons, carbon monoxide, and oxides of nitrogen, and, during lean operation, oxides of nitrogen are removed with the combination of the non-thermal plasma and the selective catalytic reduction catalyst. Such as system provides improved fuel economy from a nominally stoichiometrically calibrated engine by allowing operation on a lean air/fuel mixture under certain conditions, such as, e.g., under steady-state highway operation, without loss of emission control capability, particularly that of oxides of nitrogen

Corona discharge devices useful in the invention include, but are not limited to, those having generally cylindrical symmetry and, in most cases, at least two concentric electrodes. At least three general design alternatives for corona discharge devices that have generally cylindrical symmetry exist. Three general design alternatives are illustrated in Figs. 6, 7, and 8. Fig. 6 is a cross-section of a cylindrical corona discharge device having concentric cylindrical electrodes inner electrode 41 and outer electrode 42. The device 40 typically includes a ferrule 44 in the base 47, which provides a gas seal, and threads 46 or other means for mounting the device 40 in the exhaust pipe 12 or shunt 31.

The inner electrode 41 is surrounded by a dielectric layer 43, which prevents breakdown, and maintains the non-thermal plasma. It is important for the overall efficiency of the device to have the predominant voltage across the "air" gap 45 of the device. Because the dielectric layer 43 in the corona discharge device shown in Fig. 6 is located in a region  
5 where high electric fields occur, the dielectric constant of the layer should be in the range of from about 4 to about 10 to limit the voltage drop across the dielectric layer. As a result, most of the voltage is across the "air" gap of the corona discharge device, and the efficiency of the device is maintained.

However, depending on the design of the corona discharge device, the  
10 dielectric, due to its conductivity, may act as a shunt conductive path to ground that effectively reduces the current to the corona discharge. Where the corona discharge device is subject to shunt capacitive losses in the region of the base 47 that increase proportionally with increasing dielectric constant, a decision is often required during the design of a corona discharge device of this type, as to the relative importance of the voltage drop across the  
15 dielectric and the shunt capacitive losses in the base region. In practice, the careful design of the corona discharge device will minimize the effective area of the shunt capacitance and provide the lowest practical dielectric constant.

Resistive losses also occur in dielectrics at high temperatures, and, thus, a dielectric material must be selected with sufficiently low conductivity, so that the resistive  
20 losses are acceptably low, or the corona discharge device must be operated in a chamber or shunt path off of the exhaust system to allow operation at a lower temperature. Other design issues include EMI, resistance to corrosion in the corrosive, high temperature environment, contamination, condensation of water during engine cool down, and vibration. For EMI, the corona discharge device and its power supply and leads must have sufficient  
25 shielding to meet automotive system EMI requirements.

Material selection should account for high temperature behavior and the ability to withstand a corrosive environment that could limit the design life or performance of the device, e.g., high temperature diffusion of contaminants into the dielectric that could lower the resistivity of the dielectric below the required value for maximum efficiency, and  
30 possibly result in the formation of a partial or complete short circuit in the device. However, the corona discharge itself should naturally reduce or eliminate contamination of the device.

The need for a high dielectric constant can be reduced or eliminated by placing the dielectric layer 43 on the inner surface of the outer electrode 42. Such a device  
35 50 is illustrated in Fig. 7. Because the electric fields that occur in the region of the outer electrode 42 are relatively low compared to those in the region of the center electrode 41, a

dielectric material having a low dielectric constant, i.e., on the order of from about 2 to about 3, may be used for the dielectric layer. This reduces shunt capacitive losses, while maintaining a limited voltage drop across the dielectric layer.

It is also possible to use the exhaust pipe 12 or exhaust shunt 31 as a distant  
5 ground for the corona discharge device, eliminating the need for an outer electrode. Such a distant ground corona discharge device 60 is shown in Fig. 8, and only requires an inner electrode 41, preferably, with a sharp or small radius tip to promote breakdown, a dielectric insulator 43, and a base 47, which typically includes a ferrule 44 to provide the required seal and strain relief. Because a distant ground device is only subject to base loss  
10 considerations, such a device also allows the use of dielectric materials having a low dielectric constant.

It may also be desirable in some applications to include one or more flame  
arresters in the design of the corona discharge device. Such a device is shown in Fig. 9, in  
15 which a corona discharge device 50 having an outer electrode 42 coated with a dielectric layer 43 is capped with a flame arrester 48 in the form of a wire screen. Such a flame arrester will prevent the ignition of exhaust gases containing fuel and oxygen during engine starts and misfires.

The corona discharge devices shown in Fig. 6 and Fig. 7 resemble a large  
sparkplug in appearance. They have a center electrode 41 with a diameter of about 0.1 to  
20 about 0.3 cm. The inner electrode 41, is inserted into and held in place by a hole in the dielectric layer 43 in the base 47. The dielectric material may be applied to either or both of the electrodes by anodizing, deposition, or other appropriate process known in the art. In devices where the dielectric layer 43 is positioned on the inner surface of the outer electrode 42, the dielectric layer 43 basically forms a cup having a hole in its base to position the  
25 inner electrode. The outer electrode has an inner diameter of about 1 to about 2 cm and a length of about 1.5 to 3 cm. The dielectric layer has a base and wall thickness of about 1 to about 3 mm, which is chosen to provide the desired dielectric strength at the operating voltage of the corona discharge device.

Fig. 15 is a cross section of a preferred embodiment of the corona discharge  
30 device 130 of the invention. The corona discharge device illustrated in Fig. 15 comprises a center high voltage electrode 131, a high temperature ceramic 133 that totally surrounds the high voltage electrode at the corona discharge end, a ground electrode 132 that also serves as the mounting element and seal surface to the gas flow region, and a thermally conductive shield 136 having apertures 134 over the corona discharge region 135. The shield serves  
35 several purposes: it acts as the ground surface for the corona discharge, it thermally shields the ceramic dielectric barrier from the bulk of the high temperature gas flow, and it allows

gas to flow in and out of the corona discharge region through slits in its surface from and to the core exhaust gas flow. The shield is thermally and electrically grounded to the exhaust manifold in order to effectively heat sink it, as the temperature of the exhaust pipe wall in an automobile is typically 200°C less than the core exhaust gas temperature. Thus, an effective thermal ground to the exhaust pipe wall can significantly reduce the upper temperature limit to which the ceramic element is exposed. In addition, with the use of a ceramic with high thermal conductivity properties like alumina, the ceramic itself provides a good heat sink path to the manifold wall. This heat sink action serves to further reduce the temperature of the ceramic, and allows for a higher dielectric breakdown voltage, increasing the material selection options for the ceramic.

Furthermore, in order to effect one piece construction, to create effective gas seals, and to preclude mechanical failures of the assembly the coefficients of expansion of the center electrode, the ceramic, and the mounting element/ground must be carefully matched. For example, in a typical case the choice of the ceramic might be electronic grade alumina. The center electrode should be chosen to have a coefficient of linear expansion greater than the ceramic so that it maintains the ceramic in compression. Useful materials having the proper coefficient of expansion include tungsten and molybdenum. The mounting element may also be formed from, for example, a typical FeNi sparkplug alloy, having a coefficient of linear expansion less than that of the ceramic, which will also maintain the ceramic in compression. The seals between these elements can be made, for example, by the use of a solder glass, appropriately coated on the regions between the elements to form the required seal. The assembly is then fired to effect the dual purpose of forming a permanent gas and a mechanical seal.

The end of the center high voltage electrode is appropriately curved, so that the electric field formed at its surface is not significantly larger than the electric fields formed along its adjoining surfaces. This curvature is employed so that dielectric breakdown is not promoted in this region of the electrode/dielectric. The gap region between the outer surface of the dielectric and the inner surface of the ground shield for operation at near atmospheric pressure of the devices illustrated in Figs. 6 and 7 should be about 1 to about 1.5 mm in width, which corresponds to a breakdown field of between about 3 to about 4 kV and a field strength of about 25 to about 50 kV/cm at normal atmospheric pressure.

As with the corona discharge device shown in Fig. 6, the corona discharge device illustrated in Fig. 15 comprises generally cylindrical concentric electrodes 131 and 132 and at least one dielectric layer 133 between inner electrode 131 and outer electrode 132, which, again, prevents point breakdown and maintains the non-thermal



plasma. In this embodiment, outer electrode 132 is a perforated metal cylinder, where the perforations 134 may be of any form that allows for a sufficient amount of gas to pass through the perforations 134, and enter the corona discharge region 135. Preferably, as shown in Fig. 16, the perforations are in the form of slots 141. The end 136 of the corona discharge device 130 may be open in the manner illustrated in Fig. 6, but is preferably closed, as shown in Fig. 15. Most preferably, as shown in Fig. 15, the end 136 of corona discharge device 130 is curved in a manner that matches any curvature at the end of inner electrode 131. That is, the curvature of the end 136 of outer electrode 132 is substantially parallel to that of the end of inner electrode 131.

10 As with the other embodiments of the corona discharge device described above, the dielectric layer may be placed adjacent to either the inner electrode, as shown in Fig. 6 or the outer electrode, as shown in Fig. 7. In a preferred embodiment, two layers of dielectric 151 and 152 are used as shown in Fig. 17. In this embodiment, a first dielectric 151 is placed adjacent to, and preferably covers all of inner electrode 153. In addition, a  
15 second dielectric 152 is placed adjacent to the inner surface of outer electrode 154, such that the air gap 155 required to form the corona discharge is formed between the two dielectrics.

In a further embodiment of the corona discharge device, as shown in Fig. 18, the slots 162 in the outer electrode 161 may have louvers 163. The louvers 163 help to direct gas through the slots 162 and into the corona discharge within corona discharge  
20 device, enhancing the exchange of gas. Because the louvers 163 may make the operation of corona discharge device sensitive to its position within the gas stream, the corona discharge device is preferably not installed with the threads 46 shown in Figs. 6, 7 and 8. Instead corona discharge device uses an indexing device, such as a pin to align the corona discharge device properly. A cap nut or other securing device, such as a spring clamp, is then placed  
25 over the corona discharge device and screwed into place on a mounting to hold the corona discharge device in place.

Under normal operating conditions, the engine produces exhaust gas pressure oscillations having a frequency of about 30 to about 100 Hz and a peak to peak variation of about 20 to about 80 percent, depending upon the location in the exhaust system. These  
30 pressure oscillations provide an effective, continuous pumping action of the  $\text{NO}_2$  produced in the non-thermal plasma into the exhaust stream. The pumping effect of the exhaust gas pumping oscillations for any of the corona discharge devices described above, where the discharge device 110 is installed at a point on the exhaust pipe 112 where the oscillations occur, in the manner shown in Fig. 13, where the discharge device 110 is mounted on a  
35 simple "T" 113 off the side of the exhaust pipe 112. The pumping effect and the total gas motion can be augmented with a plenum 114 as shown in Fig. 14. In addition, cooling fins

116 may be added to lower the operating temperature for the discharge device 110. As noted above, a cooler operating environment improves the efficiency of the corona discharge.

Particulates in the exhaust gas in which NO is oxidized to NO<sub>2</sub> may be removed before the exhaust gas is exposed to the non-thermal plasma. For example, the exhaust gas may be taken from the downstream end of a particulate trap by diverting a portion of the exhaust gas leaving the particulate trap to a remote non-thermal plasma, such as the corona discharge produced by a corona discharge device, and introducing the output of the remote non-thermal plasma reactor into the exhaust stream upstream of the outlet of the particulate trap, as shown schematically in Fig. 4. By operating the corona discharge device in exhaust gas taken from the downstream end of the particulate trap, the corona operates in a cleaner environment, substantially free from the pollutants removed by the action of the trap. This results in an improved discharge device lifetime, and substantially eliminates fouling problems that may occur when the corona discharge device is exposed to a high level of particulates.

As shown in Fig. 4, a portion of the cleaned exhaust gas stream 21 that has passed through the particulate trap 13 is taken from the rear exhaust pipe 22, and diverted to the remote non-thermal plasma reactor 23. The output 24 of the remote non-thermal plasma reactor 23 is enriched with NO<sub>2</sub> as a result of the action of the corona on the exhaust gas 21, and is introduced into the exhaust gases in the tailpipe 12 upstream of the outlet of the particulate trap 13. Because of the higher pressures in the exhaust system, pumping, such as with a Venturi (not shown), is required to accomplish direct injection of the output of a remote non-thermal plasma reactor into the exhaust gas stream.

Preferably, the oxidation of NO to NO<sub>2</sub> occurs in the exhaust upstream of the outlet of the device for removing at least one of oxides of nitrogen, hydrocarbons, carbon monoxide, and particulates by a corona discharge device, placed in either the main exhaust pipe or in a shunt path in parallel with the main exhaust gas stream, as shown in Fig. 5. As shown in Fig. 5, a corona discharge device 30 is mounted in an exhaust shunt 31 in mount 32. The exhaust shunt 31 allows a portion of the exhaust gas stream 18 to bypass a section of the exhaust pipe 12, by exiting the exhaust pipe 12 at a first point 35, typically upstream of the device for removing at least one of oxides of nitrogen, hydrocarbons, carbon monoxide, and particulates 13, and re-entering the exhaust pipe at a second point 36, which is typically upstream of the outlet of the device for removing at least one of oxides of nitrogen, hydrocarbons, carbon monoxide, and particulates 13. The exhaust pipe will preferably include a diverter or restrictive orifice 33 or other device to regulate or control the exhaust gas flow rate into the shunt. Such a shunt path is useful in that it allows the

corona discharge device to be operated in a lower temperature environment than that of the exhaust gas stream. Preferably, the heat loss of the shunt path is improved by providing an increased surface area with, e.g., cooling fins 34 or similar devices.

A lower temperature environment simplifies the design and choice of materials for the corona discharge device, particularly with regard to the electrical properties of the device during high temperature operation and its thermal design. This is particularly important, because the resistivity, loss tangent, and dielectric constant of the materials in the corona discharge device change with increasing temperatures. The change in these properties that occurs at high temperatures can seriously degrade the efficiency of the corona discharge device, decreasing the oxidation of NO, and, thus, increasing the emission of pollutants. Where a corona discharge device is operated in a high temperature environment, the choice of materials is limited to those that experience a limited degradation in electrical properties with increasing temperatures. However, where the corona discharge device is operated in a lower temperature environment, such as that of a shunt path or diesel exhaust, other, less expensive materials that possess the desired electrical properties at lower temperatures, but lack the desired properties at high temperature may be used.

Operation at lower temperatures also reduces or eliminates problems related to a mismatch in the thermal coefficient of expansion of materials in the corona discharge device, its support, and the exhaust pipe. This reduces or eliminates strain induced material and seal failures, as well as failures caused by the numerous thermal cycles the corona discharge device will experience during the lifetime of the engine.

A corona discharge device for use with the invention should preferably be capable of functioning for at least about 50,000 to about 100,000 miles in the high temperature environment of the exhaust stream of an internal combustion engine before replacement is required. Because of space limitations in modern automobiles, it is preferred that the corona discharge device have a small physical volume, i.e., on the order of the size of a typical spark plug, and require a power supply that is no larger than about 1,200 to about 1,600 cc. In certain embodiments, in addition to operating at a temperature on the order of about 800°C, the corona discharge device must meet automotive electromagnetic interference (EMI) requirements, be readily replaceable, and be capable of withstanding thousands of thermal transients of about 800°C during start-up and cool down of the engine, as well as several million smaller thermal transients in which the change in temperature is on the order of about 200°C. In a preferred corona discharge device, for use with an engine having a rated output of about 200 horsepower, about 10 to about 50 W of high frequency, high voltage average power is required, i.e., from about 1,000 to about 1,000,000 Hz and

from about 5,000 to about 20,000 V. However, under some transient operating conditions, such as engine cold or warm starts, a greater corona discharge output may be desired. In this case the corona device would require operation at higher power levels of up to 50 to 1000 watts. This transient power condition can be met by upping the frequency voltage  
5 product to the corona device by a factor of 5 to 10 for such periods, which typically range from about 30 to about 100 sec. This can be accomplished through proper corona unit high voltage power system design, and the use of control signals from the engine controller or local startup temperature readings.

It is also anticipated that, during cold start operation, it may be desirable to  
10 expose a greater amount of the exhaust stream to the non-thermal plasma produced by the corona discharge device. This may be accomplished by placing a cold start gas diverter 171 into the gas stream, as shown in Figs. 19 and 20. This diverter 171 may be a simple flap in the exhaust stream that is positioned to divert a greater flow of gas through the corona discharge device when the exhaust system is cold. The diverter 171 may be controlled by  
15 electric servos or vacuum actuators and a temperature sensor. However, the diverter 171 may be most easily positioned by using a strip of bimetallic material. As the temperature of the exhaust system increases, one side of the bimetallic material will expand more than the other, causing the diverter 171 to open, as shown by the arrows in Figs. 19 and 20, allowing more of the exhaust gas to pass through the main part of the exhaust pipe. Similarly, where  
20 a shunt 31 is used, such as that illustrated in Figs. 5 and 20, the diverter 171 can be used to force a major portion of the exhaust gas through the shunt during cold start or other specific operating conditions, but allow most of the gas to pass through the main pipe during normal operating conditions.

The corona discharge device 200 illustrated in Fig. 21 comprises a high  
25 voltage electrode with a circular end 204, which defines the outer boundary of the discharge space, a dielectric insert 205, and a ground electrode 203. The dielectric insert provides insulation between the high voltage and the ground electrode and also serves to create the dielectric region 201 between the two electrodes. The gap between the high voltage electrode and the dielectric surface is the discharge space 201. The ground electrode also  
30 serves as the mounting nut, and is equipped with mounting threads 206. The corona device is mounted onto a female threaded boss on the exhaust manifold by means of the ground electrode mounting threads. The design in Fig. 21 allows the exhaust gas to freely flow through the discharge space between the high voltage electrode and the ceramic outer surface. The upper temperature limit to which the ceramic element is exposed is minimized  
35 by heat sinking it to the ground electrode, minimizing its thickness, and selecting a ceramic

with a high thermal conductivity. Alumina ceramic is a good candidate material, possessing a high conductivity and excellent high temperature dielectric strength.

In the design shown in Fig. 21, the alumina barrier, which is only about 1 to about 2 mm thick, is heat sunk over half its surface area to the metal ground electrode, which is in turn grounded to the exhaust manifold outer wall. The heat sinking and thinness limit the upper temperature limit at which the ceramic must operate, and therefore reduces the probability of dielectric breakdown, as the exhaust manifold outer wall runs at a temperature of about 200°C less than the core flow temperature of the exhaust gas with an internal combustion engine.

A disadvantage of the design shown in Fig. 21 is the possible establishment of an arc breakdown from the high voltage electrode along the dielectric and around the outer edge of the dielectric to ground. A design improvement is shown in Fig. 22 that minimizes this effect. In this case significant portions of the edges of the dielectric 205 are raised to create a longer path along which any arc would need to traverse; thus helping to prevent breakdown. As shown two opposite gaps in this edge need to be provided to allow the exhaust gas to flow through the discharge region. In order to maintain a long surface discharge path in this case the high voltage electrode 204 is correspondingly indented. In this design, the gaps in the raised edge 207 of the dielectric need to be aligned perpendicular with the flow. One of the possible means of effecting this alignment is to index the mounting threads 206 in the corona device and its mounting boss 210 such that when the corona device is seated in the exhaust pipe 211, the gap regions are in proper alignment to the flow.

Fig. 23 illustrates a typical configuration for the present invention when used in conjunction with a modern automobile engine 11, which is preferably a lean burn spark ignition engine or a diesel engine, but may also a stoichiometric engine, i.e., one that operates on a stoichiometric air/fuel mixture. As shown in Fig. 23, engine 11 produces an exhaust gas stream 18, which passes from the engine 11 through exhaust manifold 15, and passes through exhaust pipe 12. A device for producing a non-thermal plasma 14 is preferably positioned within the exhaust gas stream 18 within exhaust pipe 12, but may also be positioned remotely or in a shunt, as discussed above. However, the device for producing a non-thermal plasma 14 is preferably positioned within the exhaust gas stream 18 upstream or at the at least one device for removing at least a portion of at least one of oxides of nitrogen, hydrocarbons, carbon monoxide, and particulates 13 in the exhaust gas, which is typically positioned such that the exhaust gas stream 18 passes through device 13. Device 13 is typically a selective catalytic reduction catalyst, particulate trap, selective catalytic reduction catalyst coated particulate trap, oxide of nitrogen storage and reduction

catalyst, oxidation catalyst, or three-way catalyst. However, where either an oxidation catalyst or three-way catalyst the device is used in the invention, the oxidation catalyst or three-way catalyst is typically positioned at position 16, downstream of device 13, which is preferably at least one of a selective catalytic reduction catalyst, particulate trap, selective  
5 catalytic reduction catalyst coated particulate trap, or oxide of nitrogen storage and reduction catalyst. The device 13 is positioned at the underbody of the automobile (not shown), and is situated in the exhaust gas stream 18 from the engine, in the exhaust pipe 12 downstream from the exhaust manifold 15, and before the muffler 17.

While it is apparent that the invention disclosed herein is well calculated to  
10 fulfill the objects stated above, it will be appreciated that numerous modifications and embodiments may be devised by those skilled in the art. Therefore, it is intended that the appended claims cover all such modifications and embodiments that fall within the true spirit and scope of the present invention.

15

20

25

30

35

## THE CLAIMS

What is claimed is:

1. An apparatus for removing at least a portion of at least one pollutant in an exhaust gas stream containing exhaust gas formed from the combustion of fuel in a lean burn engine, the apparatus comprising:
  - at least one device for removing at least a portion of at least one of oxides of nitrogen, hydrocarbons, carbon monoxide, and particulates in the exhaust gas, the device having an inlet and an outlet, wherein the device is selected from the group consisting of selective catalytic reduction catalysts, particulate traps, selective catalytic reduction catalyst coated particulate traps, oxide of nitrogen storage and reduction catalysts, oxidation catalysts, and three-way catalysts, and is positioned, such that at least a portion of the exhaust gas stream from the lean burn engine passes through the device; and
  - at least one device for producing a non-thermal plasma in at least a portion of the exhaust gas stream;
- wherein at least a portion of the exhaust gas stream is exposed to the non-thermal plasma, and at least a portion of that portion of the exhaust gas stream exposed to the non-thermal plasma is introduced into the exhaust gas stream at a point upstream of or at the at least one device for removing at least one of oxides of nitrogen, hydrocarbons, carbon monoxide, and particulates.
2. The apparatus of claim 1, further comprising at least one additional device for removing at least a portion of at least one of oxides of nitrogen, carbon monoxide, hydrocarbons, and particulates in the exhaust gas, the device having an inlet and an outlet, wherein the device is selected from the group consisting of selective catalytic reduction catalysts, particulate traps, selective catalytic reduction catalyst coated particulate traps, oxide of nitrogen storage and reduction catalysts, oxidation catalysts, and three-way catalysts, and is positioned such that at least a portion of the exhaust gas stream from the lean burn engine passes through the additional device after passing through the device for removing at least a portion of at least one of oxides of nitrogen, hydrocarbons, carbon monoxide, and particulates in the exhaust gas.
3. The apparatus of claim 2, wherein the at least one additional device is an oxidation catalyst for removing at least one of carbon monoxide and hydrocarbons.

35

4. The apparatus of claim 2, wherein the at least one additional device is a three-way catalyst for removing at least one of oxides of nitrogen, carbon monoxide, and hydrocarbons.
5. The apparatus of claim 1, wherein the lean burn engine is selected from the group consisting of lean burn spark ignition engines, compression ignition engines, and turbine engines.
6. The apparatus of claim 1, wherein at least a portion of the non-thermal plasma is positioned within the exhaust gas stream.
7. The apparatus of claim 1, wherein the device for producing a non-thermal plasma in the exhaust gas comprises a corona discharge device.
8. The apparatus of claim 7, wherein the corona discharge device comprises at least one first electrode, at least one second electrode positioned a distance from the first electrode, and dielectric material positioned between the first electrode and the second electrode.
9. The apparatus of claim 7, further comprising a high frequency power supply having an operational frequency of at least about 1,000 Hz adapted to provide electrical power to the corona discharge device.
10. The apparatus of claim 9, wherein the lean burn engine has a rated power output, and the power supply requires no more than about 0.1 percent of the rated power output of the lean burn engine.
11. The apparatus of claim 9, wherein the power supply requires no more than about 0.01 percent of the rated power output of the lean burn engine.
12. The apparatus of claim 1, further comprising an exhaust pipe attached to the inlet of the at least one device for removing at least one of oxides of nitrogen, hydrocarbons, carbon monoxide, and particulates, such that the exhaust gas stream has a direction of flow, and at least a portion of the exhaust gas stream passes through the exhaust pipe to and through the at least one at least one device for removing at least one of oxides of nitrogen, hydrocarbons, carbon monoxide, and particulates, wherein the exhaust pipe



comprises a fitting for positioning the device for producing a non-thermal plasma in the exhaust stream or a portion thereof, so that a non-thermal plasma is produced in the exhaust stream upstream of or at the at least one at least one device for removing at least one of oxides of nitrogen, hydrocarbons, carbon monoxide, and particulates.

5

13. The apparatus of claim 12, wherein the fitting has an axis that is at an angle to the direction of flow of the exhaust gas stream.

14. The apparatus of claim 1, wherein the at least one device for  
10 removing at least one of oxides of nitrogen, hydrocarbons, carbon monoxide, and particulates is a selective catalytic reduction catalyst.

15. The apparatus of claim 14, wherein the non-thermal plasma and selective catalytic reduction catalyst are configured to provide an effective operational range  
15 of at least about 500°C.

16. The apparatus of claim 14, wherein the selective catalytic reduction catalyst is a catalyst that reduces the oxides of nitrogen with at least one of hydrocarbons and ammonia.

20

17. The apparatus of claim 14, wherein the apparatus is configured and adapted for injecting at least one of hydrocarbons and ammonia into the exhaust gas stream upstream of or at the selective reduction catalyst.

18. The apparatus of claim 14, wherein the selective catalytic reduction catalyst is selected from the group consisting of precious metals, base metals on acidic supports, and solid oxides.

25

19. The apparatus of claim 18, wherein the base metals have acidic  
30 supports.

20. The apparatus of claim 18, wherein the solid oxides are acidic.

21. The apparatus of claim 18, wherein the precious metal is platinum.

35

22. The apparatus of claim 18, wherein the base metal is copper, and the acid support is a zeolite.

23. The apparatus of claim 14, wherein the apparatus is configured and adapted to oxidize NO to NO<sub>2</sub> within the non-thermal plasma at a first lower temperature, and to oxidize at least one of hydrocarbons and ammonia with oxygen at a second higher temperature.

24. The apparatus of claim 23, wherein the first lower temperature is about 100°C, and the second higher temperature is at least about 500°C.

25. The apparatus of claim 1, wherein the at least one device for removing at least one of oxides of nitrogen, hydrocarbons, carbon monoxide, and particulates is a particulate trap.

15

26. The apparatus of claim 1, wherein the at least one device for removing at least one of oxides of nitrogen, hydrocarbons, carbon monoxide, and particulates is a selective catalytic reduction catalyst coated particulate trap.

20

27. The apparatus of claim 26, wherein the non-thermal plasma is positioned in the exhaust gas stream upstream or at the selective catalytic reduction catalyst coated particulate trap.

28. The apparatus of claim 1, wherein the at least one device for removing at least one of oxides of nitrogen, hydrocarbons, carbon monoxide, and particulates is an oxide of nitrogen storage and reduction catalyst.

25  
30

29. The apparatus of claim 28, wherein the oxide of nitrogen storage and reduction catalyst is substantially free of platinum to avoid oxidation of SO<sub>2</sub>.

30. A method for removing at least a portion of at least one pollutant in an exhaust gas stream containing exhaust gas formed from the combustion of fuel in a lean burn engine, the method comprising:

35 passing the exhaust gas stream through at least one device for removing at least a portion of at least one of oxides of nitrogen, hydrocarbons, carbon monoxide, and particulates in the exhaust gas, the device having an inlet and an outlet, wherein the device

is selected from the group consisting of selective catalytic reduction catalysts, particulate traps, selective catalytic reduction catalyst coated particulate traps, oxide of nitrogen storage and reduction catalysts, oxidation catalysts, and three-way catalysts;

- 5 exposing at least a portion of the exhaust gas stream to a non-thermal plasma, and  
introducing the exhaust gas stream that was passed through the non-thermal plasma into the exhaust gas stream upstream of or at the device for removing at least one of the oxides of nitrogen, hydrocarbons, carbon monoxide, and particulates.

10 31. The method of claim 30, further comprising selecting the lean burn engine from the group consisting of lean burn spark ignition engines, compression ignition engines, and turbine engines.

15 32. The method of claim 30, further comprising operating the lean burn engine in lean burn mode continuously.

20 33. The method of claim 30, further comprising passing the exhaust gas stream through at least two devices device for removing at least a portion of at least one of oxides of nitrogen, hydrocarbons, carbon monoxide, and particulates in the exhaust gas.

25 34. The method of claim 30, further comprising positioning a first device for removing at least a portion of at least one of oxides of nitrogen, hydrocarbons, carbon monoxide, and particulates upstream of a second device for removing at least a portion of at least one of oxides of nitrogen, hydrocarbons, carbon monoxide, and particulates, such that the exhaust gas stream passes through the first device before passing through the second device.

30 35. The method of claim 30, further comprising operating the lean burn engine on a stoichiometric or rich fuel mixture when the lean burn engine is under a load that requires a increased power output, and on a lean fuel mixture when the lean burn engine is under a reduced load.

35 36. The method of claim 30, further comprising producing the non-thermal plasma using a corona discharge device, which comprises a first electrode, a second electrode positioned a distance from the first electrode, and a dielectric material positioned between the first electrode and the second electrode.

37. The method of claim 36, further comprising providing electrical power to the corona discharge device with a high frequency power supply having an operational frequency of at least about 1,000 Hz.

5 38. The method of claim 30, further comprising oxidizing NO in the exhaust stream to NO<sub>2</sub> with the non-thermal plasma.

39. The method of claim 38, further comprising oxidizing NO to NO<sub>2</sub> at a temperature of about 100°C.

10

40. The method of claim 30, further comprising selecting a selective catalytic reduction catalyst as the at least one device for removing at least a portion of at least one of oxides of nitrogen, hydrocarbons, carbon monoxide, and particulates in the exhaust gas.

15

41. The method of claim 40, further comprising positioning an oxidation catalyst downstream of the selective reduction catalyst to remove residual hydrocarbons and carbon monoxide.

20

42. The method of claim 40, further comprising positioning a particulate trap downstream of the selective reduction catalyst

43. The method of claim 42, further comprising positioning an oxidation catalyst downstream of the particulate trap

25

44. The method of claim 40, further comprising positioning a three-way catalyst downstream of the selective reduction catalyst to remove residual hydrocarbons, carbon monoxide, and oxides of nitrogen.

30

45. The method of claim 40, further comprising reducing NO<sub>x</sub> to N<sub>2</sub> by contacting the exhaust gas stream containing the NO<sub>2</sub> formed by oxidizing NO with the selective reduction catalyst.

35

46. The method of claim 45, further comprising contacting the NO<sub>2</sub> with at least one of hydrocarbons or ammonia in the selective reduction catalyst.

47. The method of claim 46, further comprising oxidizing at least one of hydrocarbons and ammonia within the selective reduction catalyst at a temperature of at least about 500°C.

5 48. The method of claim 47, further comprising oxidizing at least one of hydrocarbons and ammonia within the selective reduction catalyst at a temperature of at least about 700°C.

49. The method of claim 30, further comprising selecting a particulate  
10 trap as the at least one device for removing at least a portion of at least one of oxides of nitrogen, hydrocarbons, carbon monoxide, and particulates in the exhaust gas.

50. The method of claim 49, further comprising trapping particulates with the particulate trap, and contacting the particulates in the trap with the NO<sub>2</sub> produced  
15 in the non-thermal plasma, enhancing the oxidation of the particulates on the particulate trap surface with the NO<sub>2</sub>.

51. The method of claim 50, further comprising enhancing the oxidation of the particulates continuously with NO<sub>2</sub> to avoid blocking the particulate trap, resulting in  
20 a build-up of back pressure.

52. The method of claim 30, further comprising selecting a selective catalytic reduction catalyst coated particulate traps as the at least one device for removing at least a portion of at least one of oxides of nitrogen, hydrocarbons, carbon monoxide, and  
25 particulates in the exhaust gas.

53. The method of claim 30, further comprising selecting an oxide of nitrogen storage and reduction catalyst as the at least one device for removing at least a portion of at least one of oxides of nitrogen, hydrocarbons, carbon monoxide, and  
30 particulates in the exhaust gas.

54. The method of claim 53, further comprising storing NO<sub>2</sub> on the nitrogen storage and reduction catalyst surface during lean burn operation of the lean burn engine.

35

55. The method of claim 54, further comprising periodically operating the lean burn engine on a stoichiometric or rich air fuel mixture, releasing the oxides of nitrogen from the catalyst surface, and reducing the oxides of nitrogen to N<sub>2</sub> with a three-way catalyst.

5

56. The method of claim 30, further comprising selecting an oxidation catalyst as the at least one device for removing at least a portion of at least one of oxides of nitrogen, hydrocarbons, carbon monoxide, and particulates in the exhaust gas.

10

57. The method of claim 30, further comprising selecting a three-way catalyst as the at least one device for removing at least a portion of at least one of oxides of nitrogen, hydrocarbons, carbon monoxide, and particulates in the exhaust gas.

15

20

25

30

35

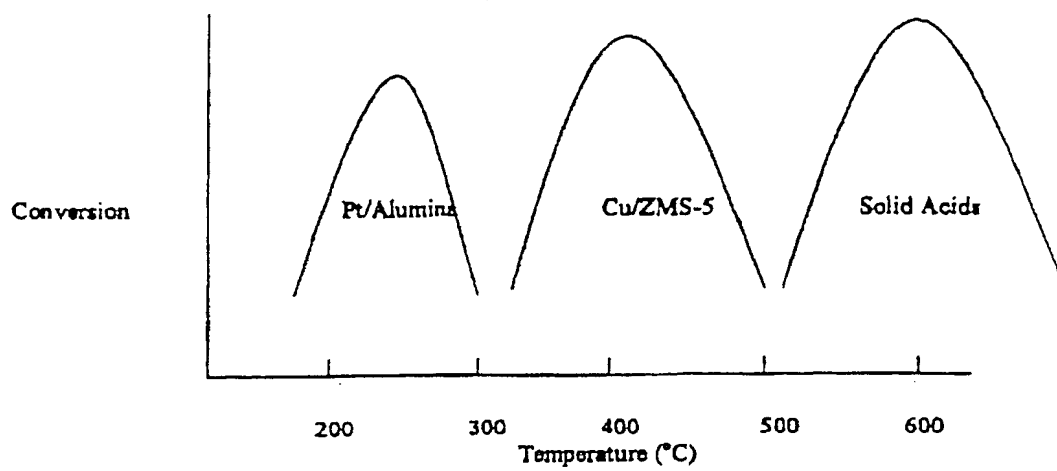

FIG. 1

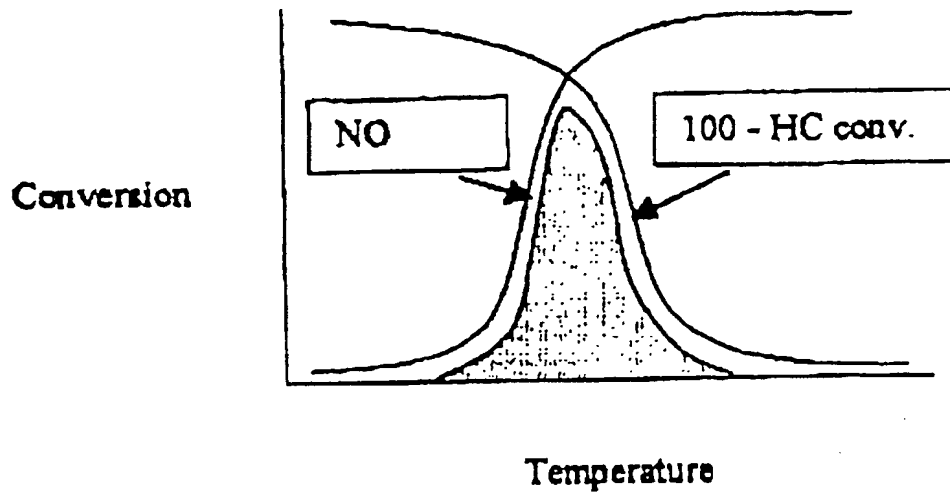

FIG. 2



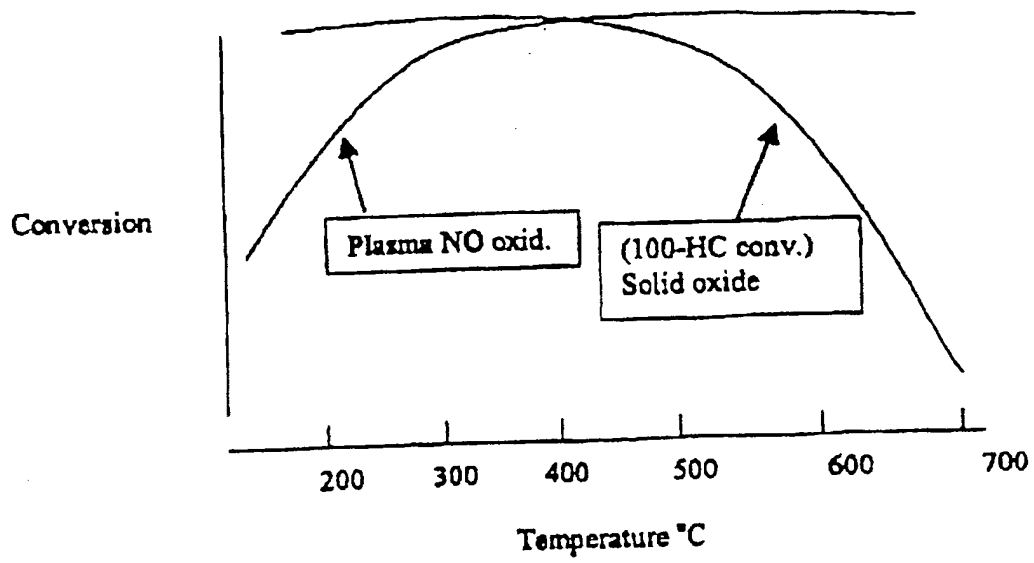

FIG. 3

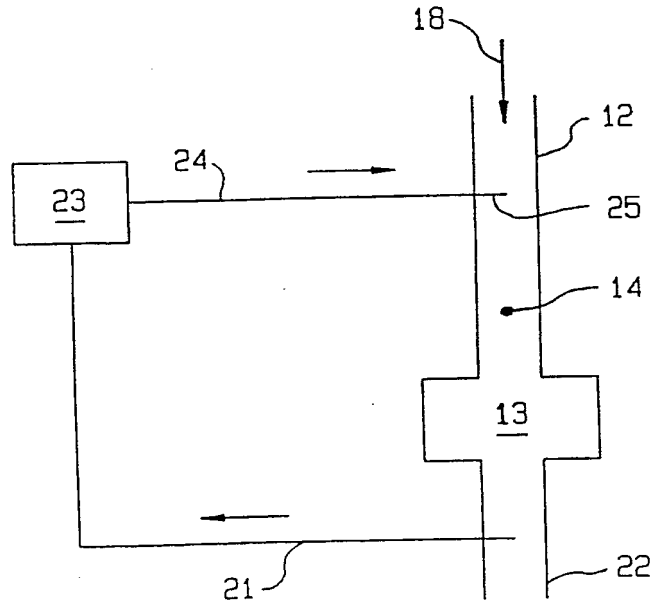

FIG. 4

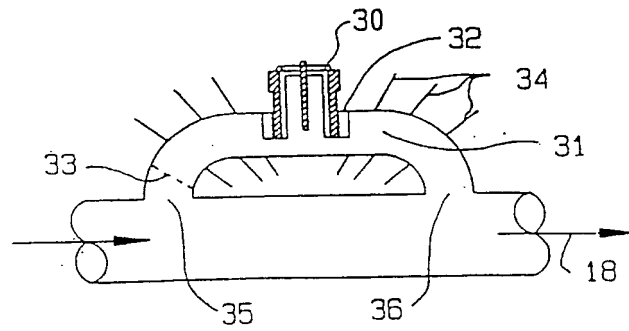

FIG. 5

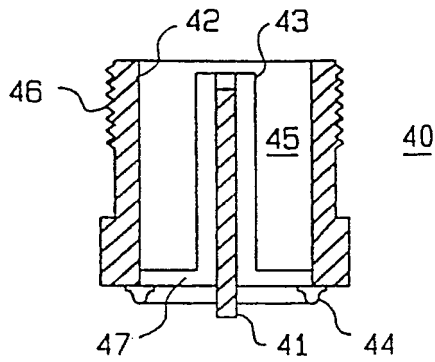

FIG. 6

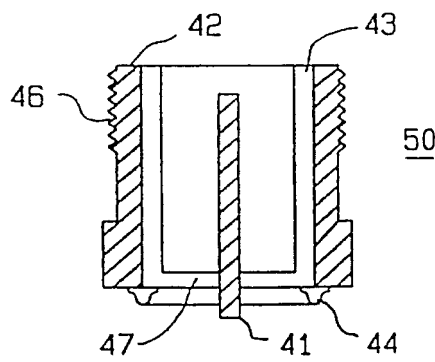

FIG. 7

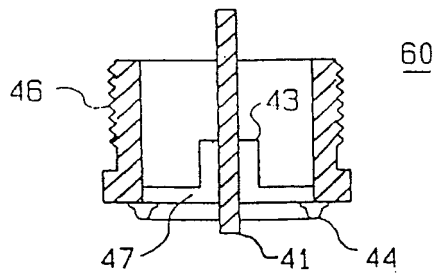

FIG. 8

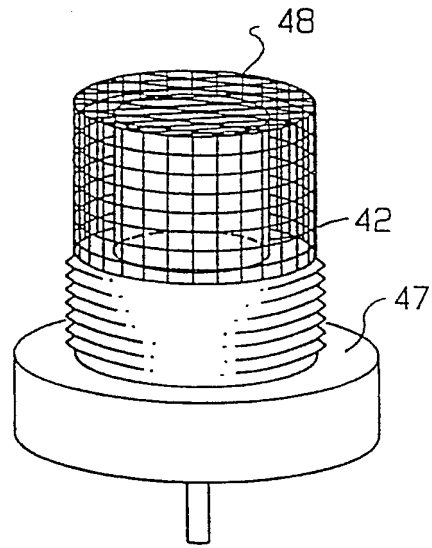

FIG. 9

6/14

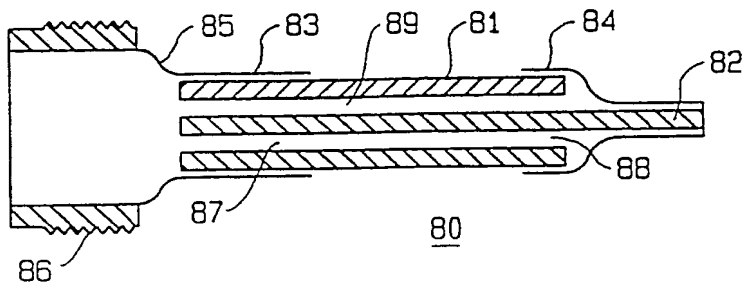

FIG. 10

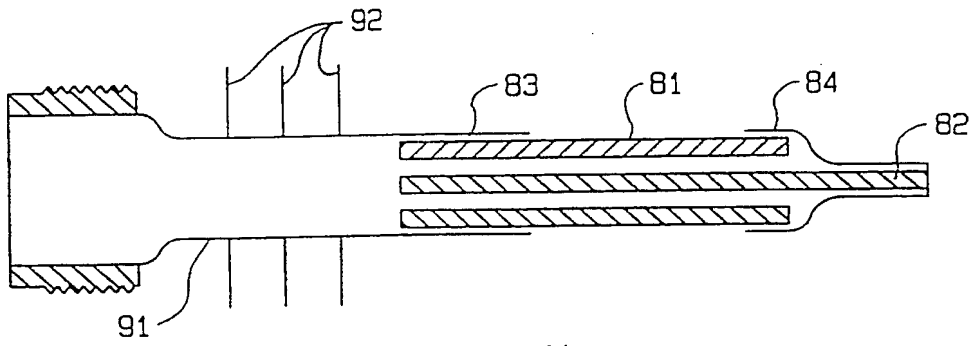

FIG. 11

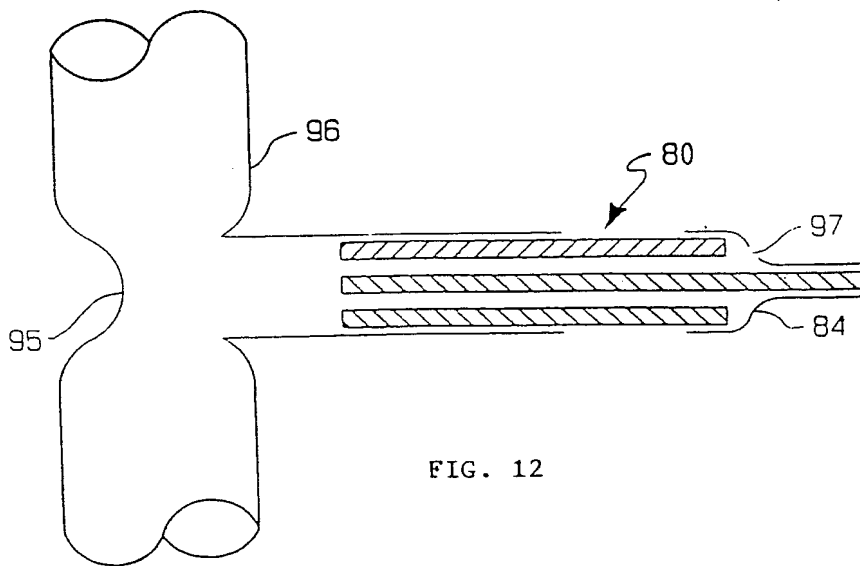

FIG. 12

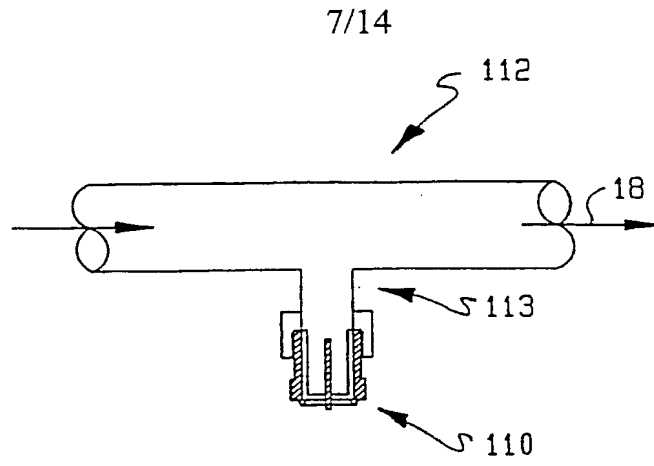

FIG. 13

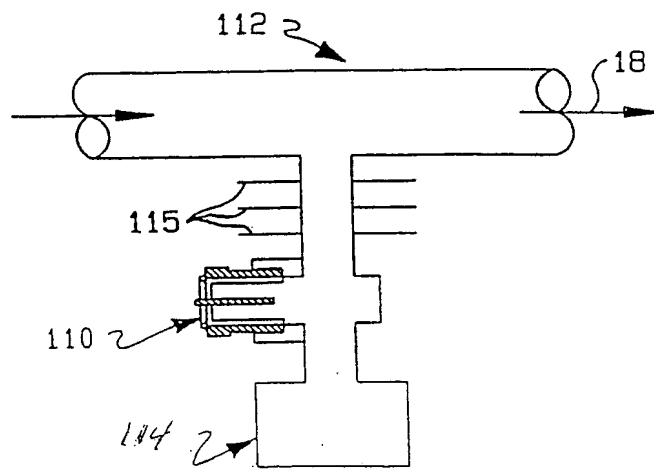

FIG. 14

8/14

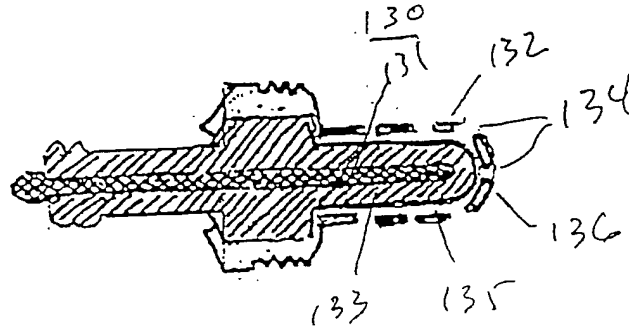

FIG. 15

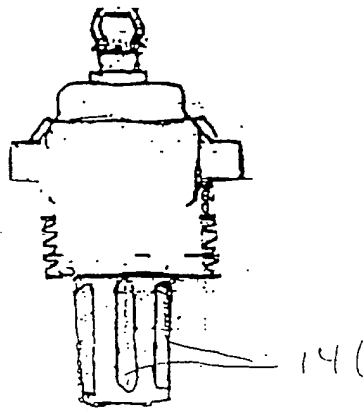

FIG. 16

9/14

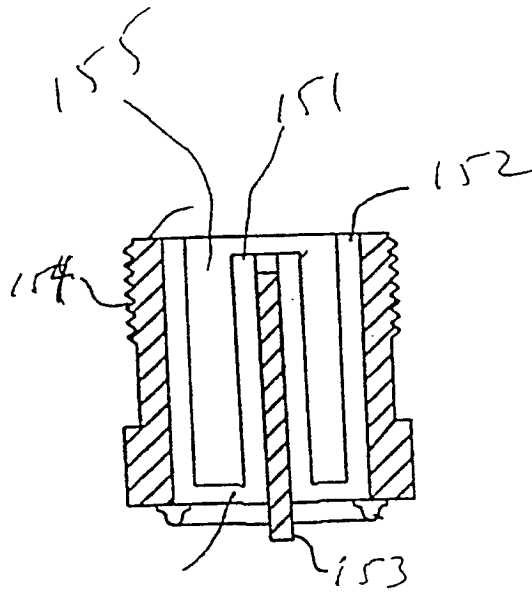

FIG. 17

10/14

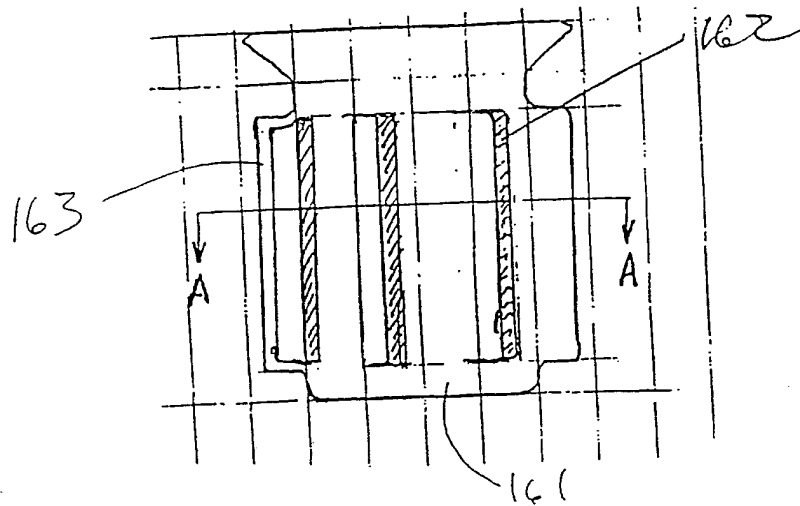

FIG. 18

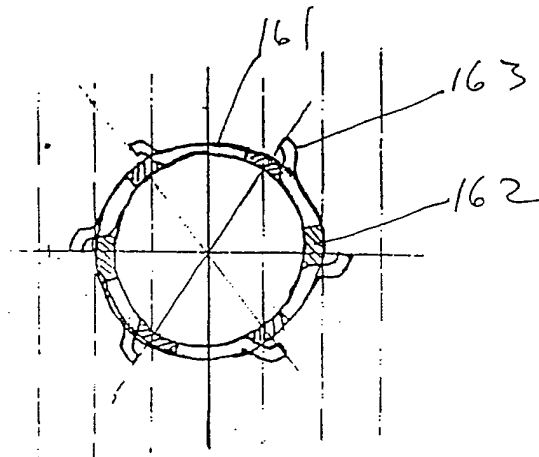

FIG. 18A



11/14

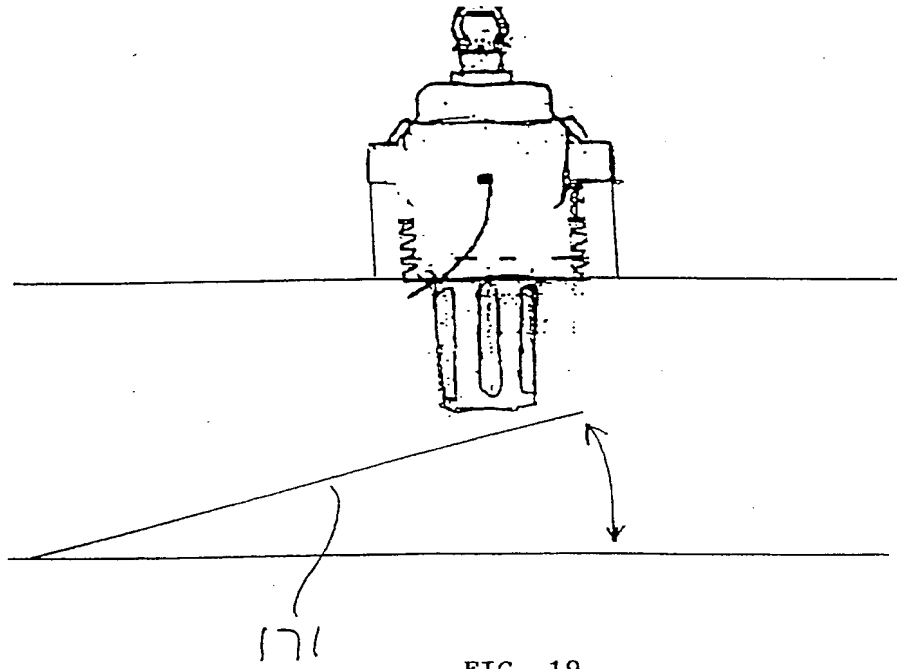

FIG. 19

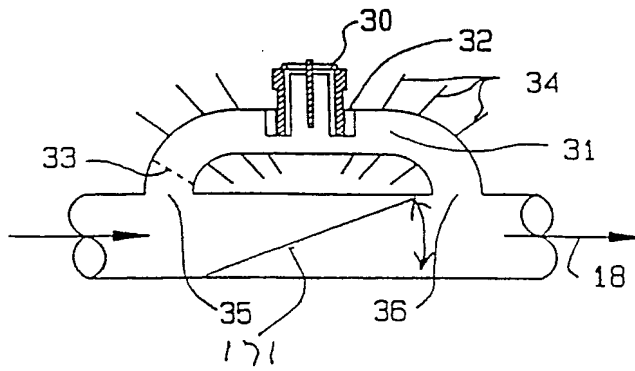

FIG. 20

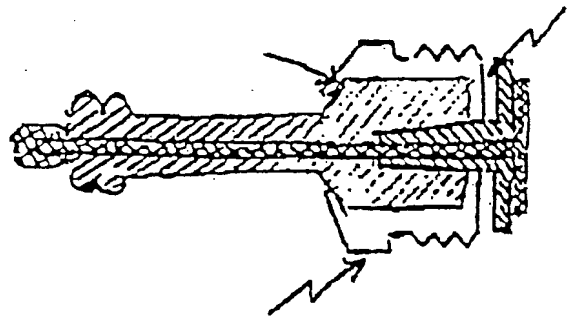

FIG. 21

13/14

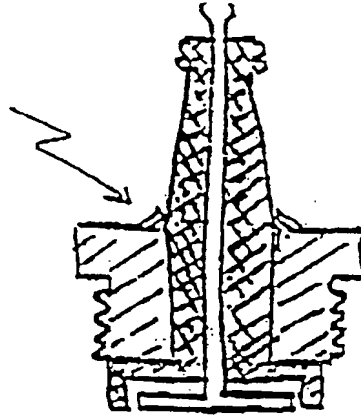

FIG. 22A

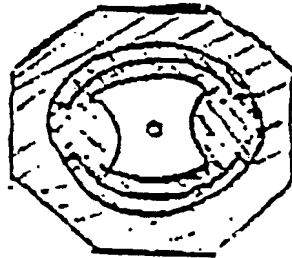

FIG. 22B

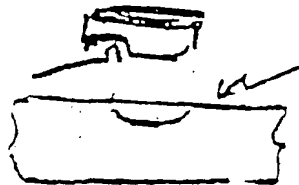

FIG. 22C

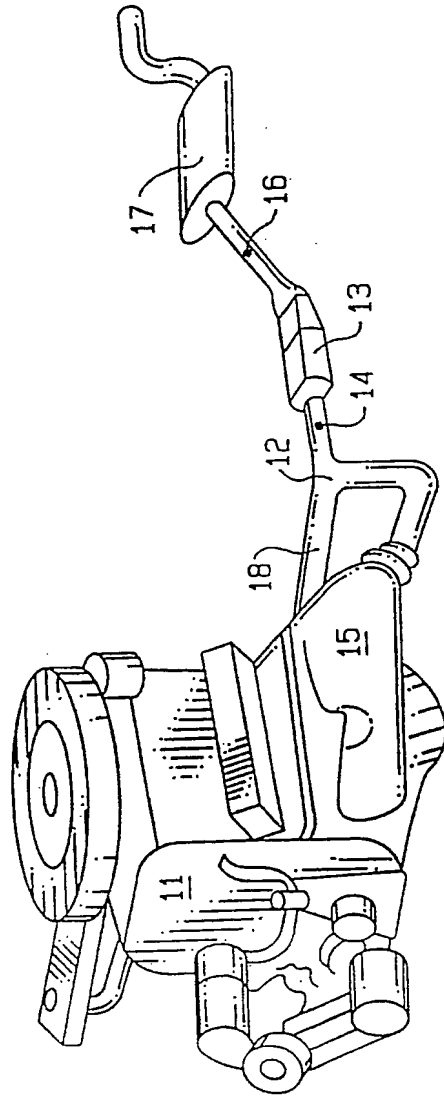

FIG. 23

PCT

WORLD INTELLECTUAL PROPERTY ORGANIZATION  
International Bureau



INTERNATIONAL APPLICATION PUBLISHED UNDER THE PATENT COOPERATION TREATY (PCT)

(51) International Patent Classification 7 : <b>F01N 3/00</b>		<b>A3</b>	(11) International Publication Number: <b>WO 00/43469</b>
			(43) International Publication Date: <b>27 July 2000 (27.07.00)</b>
(21) International Application Number: <b>PCT/US00/01574</b>		(81) Designated States: AE, AL, AM, AT, AU, AZ, BA, BB, BG, BR, BY, CA, CH, CN, CR, CU, CZ, DE, DK, DM, EE, ES, FI, GB, GD, GE, GH, GM, HR, HU, ID, IL, IN, IS, JP, KE, KG, KP, KR, KZ, LC, LK, LR, LS, LT, LU, LV, MA, MD, MG, MK, MN, MW, MX, NO, NZ, PL, PT, RO, RU, SD, SE, SG, SI, SK, SL, TJ, TM, TR, TT, TZ, UA, UG, UZ, VN, YU, ZA, ZW, ARIPO patent (GH, GM, KE, LS, MW, SD, SL, SZ, TZ, UG, ZW), Eurasian patent (AM, AZ, BY, KG, KZ, MD, RU, TJ, TM), European patent (AT, BE, CH, CY, DE, DK, ES, FI, FR, GB, GR, IE, IT, LU, MC, NL, PT, SE), OAPI patent (BF, BJ, CF, CG, CI, CM, GA, GN, GW, ML, MR, NE, SN, TD, TG).	
(22) International Filing Date: <b>21 January 2000 (21.01.00)</b>			
(30) Priority Data: <b>60/116,791 21 January 1999 (21.01.99) US</b>			
(71) Applicant: <b>LITEX, INC. [US/US]; 2235 Massachusetts Avenue, Cambridge, MA 02140 (US).</b>			
(72) Inventors: <b>CAREN, Robert, P.; 6039 Gleneagles Circle, San Jose, CA 95138-2373 (US). TRUEX, Timothy; 1241 Coronet Drive, Riverside, CA 92506 (US).</b>			
(74) Agents: <b>WEILD, David, III et al.; Pennie &amp; Edmonds LLP, 1155 Avenue of the Americas, New York, NY 10036 (US).</b>		Published <i>With international search report.</i>	
		(88) Date of publication of the international search report: <b>2 November 2000 (02.11.00)</b>	

(54) Title: **COMBINED PLASMA REACTOR CATALYST SYSTEMS FOR EFFECTIVE EMISSION CONTROL OVER A RANGE OF OPERATING CONDITIONS**

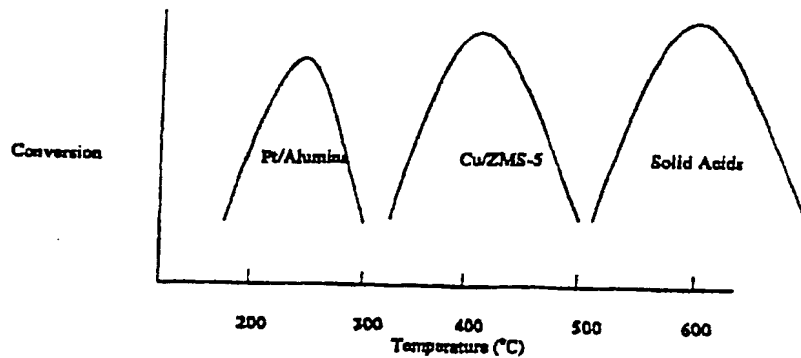

(57) Abstract

An apparatus and method for removing pollutant from exhaust gas of a lean burn engine (11). The apparatus has at least one device (13) for removing oxides of nitrogen, hydrocarbons, carbon monoxide, and particulates in the exhaust gas. The device (13) is selected from the group consisting of selective catalytic reduction catalysts, particulate traps, and three-way catalysts, and is positioned, such that at least a portion of the exhaust gas stream (18) from the lean burn engine (11) passes through the device (13); and at least one a device (14, 30, 40, 50, 60, 80) for producing a non-thermal plasma in at least a portion of the exhaust gas stream (18). A portion of the exhaust gas stream (18) is exposed to the non-thermal plasma (14, 30, 40, 50, 60, 80), and introduced into the exhaust gas stream (18) at a point upstream of the catalytic converter (13) for removing at least one of oxides of nitrogen, hydrocarbons, carbon monoxide, and particulates.

*FOR THE PURPOSES OF INFORMATION ONLY*

Codes used to identify States party to the PCT on the front pages of pamphlets publishing international applications under the PCT.

AL	Albania	ES	Spain	LS	Lesotho	SI	Slovenia
AM	Armenia	FI	Finland	LT	Lithuania	SK	Slovakia
AT	Austria	FR	France	LU	Luxembourg	SN	Senegal
AU	Australia	GA	Gabon	LV	Latvia	SZ	Swaziland
AZ	Azerbaijan	GB	United Kingdom	MC	Monaco	TD	Chad
BA	Bosnia and Herzegovina	GE	Georgia	MD	Republic of Moldova	TG	Togo
BB	Barbados	GH	Ghana	MG	Madagascar	TJ	Tajikistan
BE	Belgium	GN	Guinea	MK	The former Yugoslav Republic of Macedonia	TM	Turkmenistan
BF	Burkina Faso	GR	Greece	ML	Mali	TR	Turkey
BG	Bulgaria	HU	Hungary	MN	Mongolia	TT	Trinidad and Tobago
BJ	Benin	IE	Ireland	MR	Mauritania	UA	Ukraine
BR	Brazil	IL	Israel	MW	Malawi	UG	Uganda
BY	Belarus	IS	Iceland	MX	Mexico	US	United States of America
CA	Canada	IT	Italy	NE	Niger	UZ	Uzbekistan
CF	Central African Republic	JP	Japan	NL	Netherlands	VN	Viet Nam
CG	Congo	KE	Kenya	NO	Norway	YU	Yugoslavia
CH	Switzerland	KG	Kyrgyzstan	NZ	New Zealand	ZW	Zimbabwe
CI	Côte d'Ivoire	KP	Democratic People's Republic of Korea	PL	Poland		
CM	Cameroon	KR	Republic of Korea	PT	Portugal		
CN	China	KZ	Kazakstan	RO	Romania		
CU	Cuba	LC	Saint Lucia	RU	Russian Federation		
CZ	Czech Republic	LI	Liechtenstein	SD	Sudan		
DE	Germany	LK	Sri Lanka	SE	Sweden		
DK	Denmark	LR	Liberia	SG	Singapore		
EE	Estonia						

INTERNATIONAL SEARCH REPORT

International application No.  
PCT/US00/01574

A. CLASSIFICATION OF SUBJECT MATTER

IPC(7) : FO1N 3/00  
US CL : Please See Extra Sheet.

According to International Patent Classification (IPC) or to both national classification and IPC

B. FIELDS SEARCHED

Minimum documentation searched (classification system followed by classification symbols)

U.S. : 60/275, 274, 276, 287, 288, 289, 299, 301, 303, 304, 308; 204/173, 179, 168; 422/168, 169, 186.04

Documentation searched other than minimum documentation to the extent that such documents are included in the fields searched  
NONE

Electronic data base consulted during the international search (name of data base and, where practicable, search terms used)  
NONE

C. DOCUMENTS CONSIDERED TO BE RELEVANT

Category*	Citation of document, with indication, where appropriate, of the relevant passages	Relevant to claim No.
X	JP 405332128 A (SUZUKI) 14 December 1993, see Abstract, and Figures 1-7.	1-16, 18-57
X	US 5,746,984 A (HOARD) 05 MAY 1998, See Abstract, Figures 1-5, col. 3, lines 25-68; col. 4, lines 1-68; col. 5, lines 1-68; col. 6, lines 1-68; col. 7, lines 1-68; col. 8, lines 1-68; col. 9, lines 1-15.	1-16-18-57
X	US 5,474,747 A (HAYASHI et al.) 12 December 1995, See Figures; columns 3-12.	1-16, 18-57
Y	US 5,369,956 A (DAUDEL et al.) 06 December 1994, see entire document.	17

Further documents are listed in the continuation of Box C.  See patent family annex.

* Special categories of cited documents:	*T* later document published after the international filing date or priority date and not in conflict with the application but cited to understand the principle or theory underlying the invention
*A* document defining the general state of the art which is not considered to be of particular relevance	*X* document of particular relevance; the claimed invention cannot be considered novel or cannot be considered to involve an inventive step when the document is taken alone
*E* earlier document published on or after the international filing date	*Y* document of particular relevance; the claimed invention cannot be considered to involve an inventive step when the document is combined with one or more other such documents, such combination being obvious to a person skilled in the art
*L* document which may throw doubts on priority claim(s) or which is cited to establish the publication date of another citation or other special reason (as specified)	*A* document member of the same patent family
*O* document referring to an oral disclosure, use, exhibition or other means	
*P* document published prior to the international filing date but later than the priority date claimed	

Date of the actual completion of the international search  
28 MARCH 2000

Date of mailing of the international search report  
11 JUL 2000

Name and mailing address of the ISA/US  
Commissioner of Patents and Trademarks  
Box PCT  
Washington, D.C. 20231  
Facsimile No. (703) 305-3230

Authorized officer

THOMAS E. DENION *Diana Smith*  
Telephone No. (703) 308-2623

## INTERNATIONAL SEARCH REPORT

International application No.  
PCT/US00/01574

## C (Continuation). DOCUMENTS CONSIDERED TO BE RELEVANT

Category*	Citation of document, with indication, where appropriate, of the relevant passages	Relevant to claim No.
A	US 5,806,305 A ( MILLER et al.) 09 September 1998, see entire document.	1-57
A	US 4,945,721 A (CORNWELL et al.) 07 August 1990, see entire document.	1-57
A	US 5,842,341 A (KIBE) 01 December 1998, see entire document.	1-57



INTERNATIONAL SEARCH REPORT

International application No.  
PCT/US00/01574

A. CLASSIFICATION OF SUBJECT MATTER:  
US CL :

60/275, 274, 276, 287, 288, 289, 299, 301, 303, 304, 308; 204/173, 179, 168; 422/168, 169, 186.04